

ENGR 210 Lab 12

Frequency Response of Active RC Filters

You have studied some simple filters that used capacitors and resistors. However, these filters have several limitations. One is that the frequency roll-off of a passive filter does not occur very rapidly. Another is that the frequency response depends upon the load that is attached to the filter— in general you don't want the frequency response to change when you connect different instruments or equipment. In this lab you will examine several types of filters that incorporate op amps. You will also use a band pass filter to remove interference (hum) from a signal.

A. BACKGROUND

1. Band Pass Filter with an Op Amp Buffer

You should have built and measured the performance of a band pass filter that consisted of a high pass filter in series with a low pass filter, as shown in Figure 1, in the previous lab. The frequency response for this filter is significantly different from a simple sum of the separate filter responses since the second circuit loads the first. One of the great applications of the operational amplifier is to use an op amp buffer amplifier to isolate two circuits so that the second is not loaded by the first. In this lab you will examine a bandpass filter where the two filter sections are isolated by inserting an op amp buffer, as shown in Figure 2.

2. Active Filters

An active filter is a circuit that includes an op amp as well as having the characteristics of a filter. Recall the circuits for passive high pass and low pass filters. Their circuit diagrams are shown in Figure 3. Note that in each case a load resistor, R_L , has been added to the circuit to make it describe a more realistic situation (there will always be a load on the output of a filter circuit). The frequency characteristics of the filter are dependent upon the load resistor, which is hardly a desirable feature. In this lab you will study a variation of the low pass filter, namely, an active low pass filter as shown in Figure 4. Active filters include an op amp as an integral part of the circuit. The effect of the op amp is two-fold. First, it serves as the source of current for the load that follows the filter, thus eliminating the effect of the load resistance on the characteristics of the filter and, second, it permits adding positive gain to the filter.

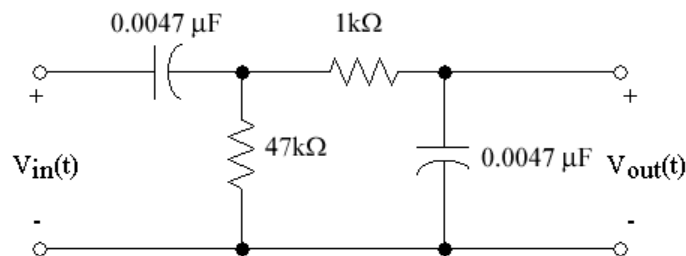

Figure 1. Band pass filter.

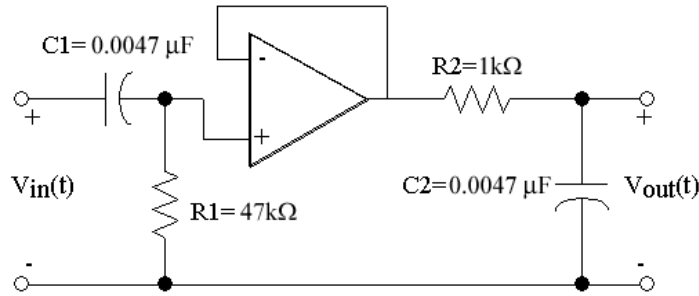

Figure 2. Buffered Band pass filter

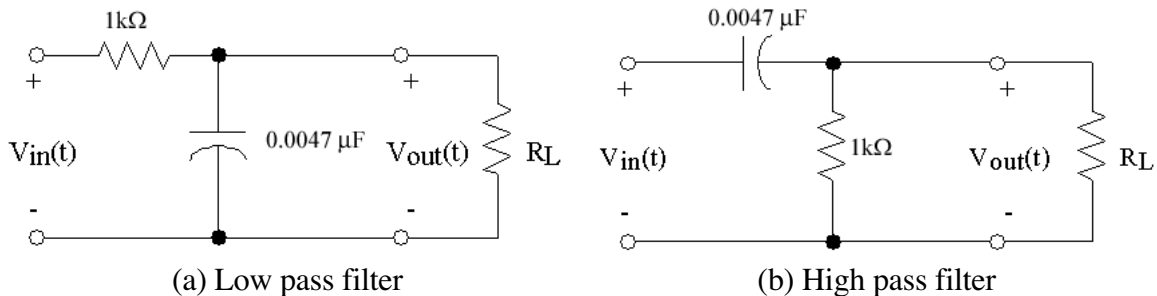

Figure 3. Passive filters.

Note that in the circuit of Figure 4 there is a capacitor in the feedback loop. This circuit will behave similar to the low pass filter of Figure 3, but with a different cutoff frequency. (Note that the component values in the circuit of Figure 4 are not the same as those in Figure 3.) This is primarily because of non-ideal characteristics of the 741 op amp.

The filter circuits of Figure 3 and Figure 4 are called **first order filters** and they have similar abilities to reject frequencies past the cutoff frequency, i.e., their frequency response rolls off at the same rate. There will be occasions when you would like to have better frequency rejection than is provided by a first order filter. (Perhaps the signal that you are interested in is corrupted by lots of noise.) A filter such as that shown in Figure 5 can provide this increased attenuation of the high frequencies. Note that this filter includes a capacitor in the input network as well as in the feedback network. Such a filter is called a **second order filter**.

3. Active "Notch" Filter

As you will quickly learn - probably the first time that you are required to use a sensor to obtain information from a system - a common problem that one encounters is the presence of 60 Hz "hum" on the output of the sensor. (You have probably already experienced this problem on your AM car radio when driving under a high voltage transmission line.) The origin of the hum is the 60 Hz power lines that supply all electrical power in the U. S. An example of the problem is shown in Figure . In Figure (a), a 500 mV, 5 Hz signal with 250 mV of hum superimposed is shown. In Figure (b) the hum has been removed with some attenuation of the desired signal.

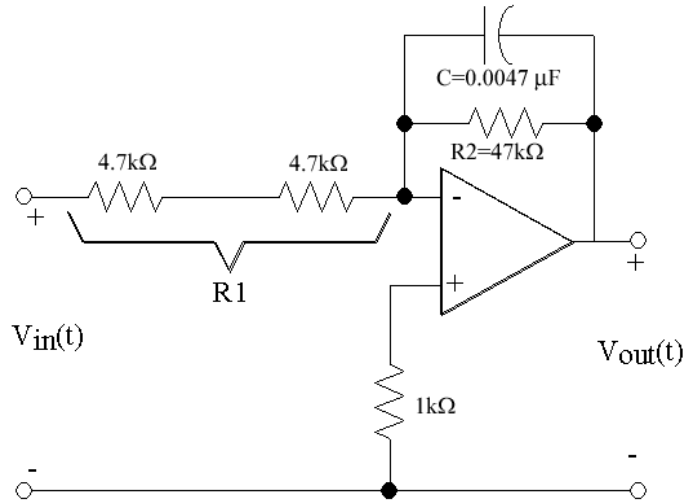

Figure 4. First Order Active low pass filter.

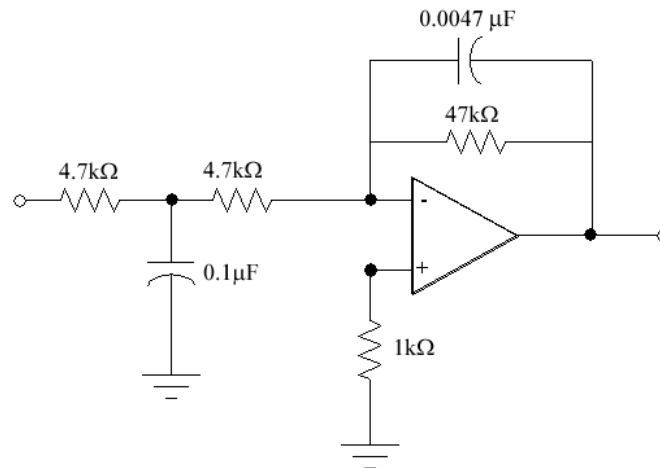

Figure 5. Second order Active low pass filter.

The hum in Figure (a) has been removed by a “notch” filter. A notch filter is a circuit having a very high attenuation for a selected frequency and very little attenuation for other frequencies. A notch filter is the inverse of a bandpass filter. There are many types of notch filters and they are typically named after their inventor. One such filter, called a Wien bridge circuit, is shown in **Error! Reference source not found.** You will study the Wien Bridge circuit in this lab. You may wish to determine the transfer characteristic of this circuit to test your understanding of phasor analysis, although this is not required.

B. LAB PREPARATION

Transfer functions are typically very tedious to derive so they are provided here for you. However, you will be required to determine the frequency dependent behavior of their magnitude and phase.

The transfer function, $H(j\omega)$, for the active low-pass filter circuit in Figure 4 can be mathematically shown to be

$$\frac{V_{out}}{V_{in}} = -\frac{R_2}{R_1} \cdot \frac{1 - j\omega R_2 C}{1 + (\omega R_2 C)^2} \quad (1)$$

where R_1 is the sum of the input resistances and R_2 is in parallel with the capacitor C across the op-amp. The resultant expressions for the magnitude and angle of $H(j\omega)$ are given in Data Table 1.

NOTE: The inverting input of the op-amp introduces a 180° phase shift at the output in addition to the phase shift due to the filter.

The transfer function, $H(j\omega)$, for the buffered band pass filter shown in Figure 2 can be mathematically shown to be

$$\frac{V_{out}}{V_{in}} = \frac{\omega^2 R_1 C_1 (R_1 C_1 + R_2 C_2) + j\omega R_1 C_1 (1 - \omega^2 R_1 C_1 R_2 C_2)}{(1 - \omega^2 R_1 C_1 R_2 C_2)^2 + \omega^2 (R_1 C_1 + R_2 C_2)^2} \quad (2)$$

where R_1 and C_1 are the input components; R_2 and C_2 are the output components. The phase angle goes from $+90$ degrees for very low frequencies to -90 degrees at very high frequencies. The peak output occurs at about 4650 Hz. The expressions for the magnitude and angle of $H(j\omega)$ are given in Data Table 1.

The phase of the output wave relative to the input wave can be determined using a procedure similar to that used for measuring the period of a wave. Figure 6 shows two waveforms which represent the input to and output from a circuit displayed on an oscilloscope. Note first that the two signals have the same period and, therefore, the same frequency; however, they are shifted in time relative to each other. You will measure this time shift between the two signals, and then calculate the corresponding phase shift.

As shown in Figure 6, set the t_1 time cursor at a location where the input signal crosses the time axis with a positive slope. Then set the t_2 time cursor to the first following point at which the output signal crosses the time axis with a positive slope. Since, in one period the phase of a periodic wave changes by 2π radians or 360° , the phase shift, $\Delta\phi$, is given by

$$\Delta\phi(\text{radians}) = \frac{t_1 - t_2}{T} \times 2\pi \quad (3)$$

or

$$\Delta\phi(\text{degrees}) = \frac{t_1 - t_2}{T} \times 360^\circ. \quad (4)$$

In this lab you will always measure t_2 for the output waveform, and t_1 for the input waveform. The resulting phase shift is often called the delay of a filter.

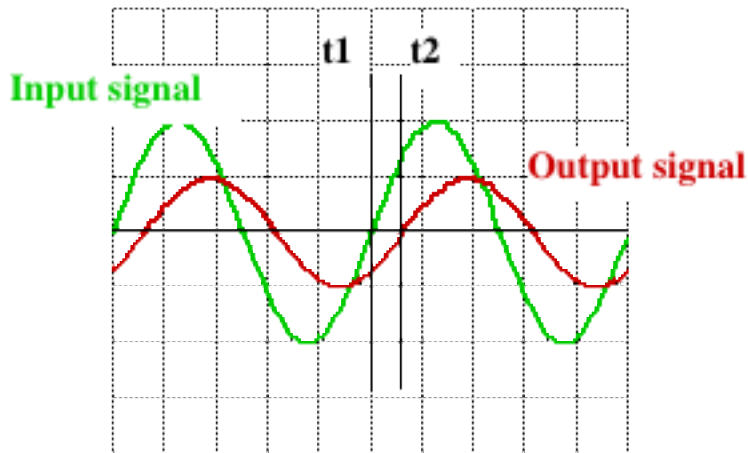

Figure 6. Measurement of phase shift.

VERY IMPORTANT: Be careful of the sign of the time delay in calculating delay. Note that the scope will calculate $t_2 - t_1$, which is the opposite sign of the expression in equations (3) and (4). Also, many times you will get angles between -270° and -360° when the actual angle should be their complement, i.e., $-270^\circ + 360^\circ = +90^\circ$ and $-360^\circ + 360^\circ = 0^\circ$ respectively. When in doubt as to whether you need to take a complement look at the results you derived for these filters.

C. LAB INSTRUCTIONS

Note: This lab will require the special “noise” functions of the function generators (USHUM) as used in lab 8. Some units do not have this feature, so be sure to check the function generator before getting too comfortable.

PART 1: Buffered band pass filter.

1. Build the circuit shown in Figure 2. Use a 741 op amp and **be sure to connect the power supply**. Use $\pm 15\text{V}$ for $\pm V_{CC}$. You should check the operational status of the 741 before using it. (The pinout diagram for the 741 is shown in Figure 7.)

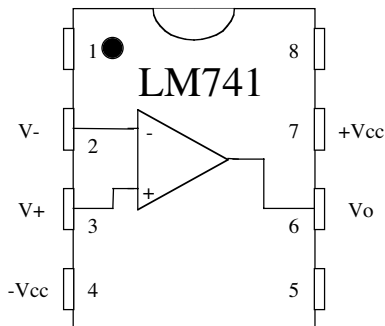

Figure 7. Pinout for 741 op amp.

2. Set up CH1 of the oscilloscope for AC coupling and an x10 probe. Set the probe itself to x10 if it has a switch. Connect the CH1 probe to the output of your circuit. Connect the output of the Function Generator to CH2 using a BNC Tee and a BNC cable. Set the Waveform Generator output impedance to HIGH Z.
3. Connect the Function Generator to the input of your circuit using the BNC to clip adapter in your cable kit. Set the generator output to produce a 100 Hz, sinusoidal, 5 V_{pp} output. **BE SURE TO PUT THE FUNCTION GENERATOR IN HIGH-Z MODE!!!!**

4. Measure and record $V_{in,PP}$, $V_{out,PP}$, the period of the input signal that you are using, and the time shift between the output and input at the frequencies listed in Data Table 2. Record your measured data for all listed frequencies there.

Part 2: Active low pass filter.

1. Build the active first order low pass filter circuit shown in Figure 4. **Keep the power supply output turned off while assembling the circuit.** NOTE: After completing a set of measurements on this circuit you will be adding a capacitor between the two $4.7k\Omega$ resistors as shown in Figure 5 for step 4, so be sure to leave adequate space.
2. Connect the oscilloscope to the input and output of the Function Generator as in Part 1. Connect the Function Generator to the circuit input and set the generator to produce a 200 Hz, $2 V_{pp}$ output.
3. Measure $V_{in,PP}$, $V_{out,PP}$, the period of the input signal that you are using, and the time shift between the output and input at the frequencies listed in Data Table 3. Record your data in Data Table 3 for all listed frequencies.
4. Connect a $0.1 \mu F$ capacitor into the circuit as shown in Figure 5 and repeat Steps (2) and (3) above, recording your data in Data Table 4.

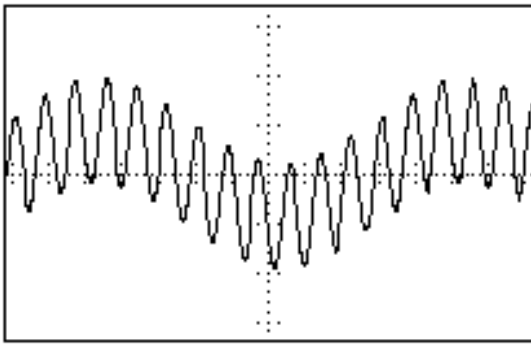

(a) Signal with 250 mV hum

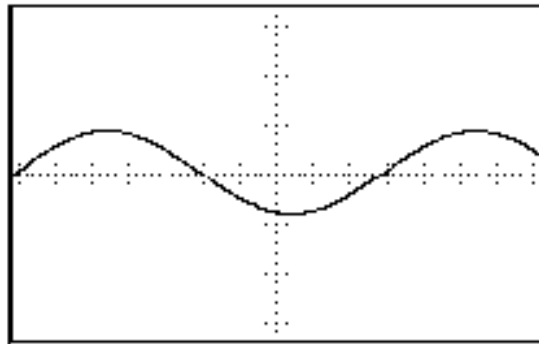

(b) Signal with hum removed

Figure 9. Example of effect of 60 Hz hum on 500 mV, 5 Hz signal.

Part 3: 60 Hz Notch Filter

1. Build the circuit shown in 8.

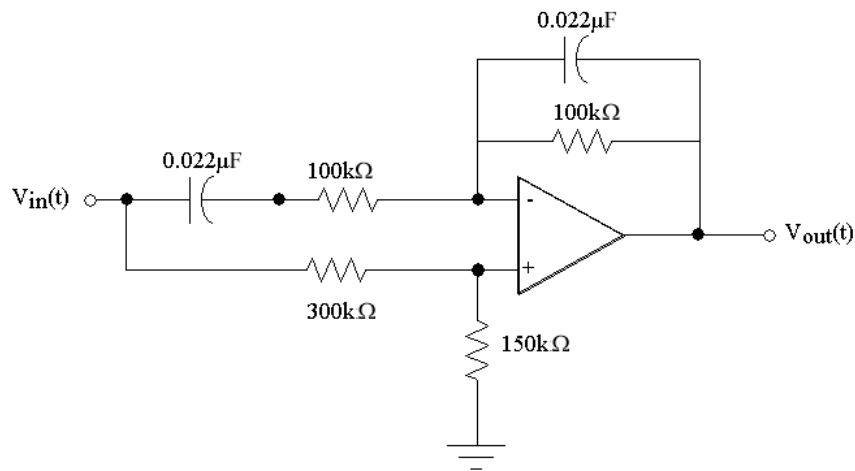
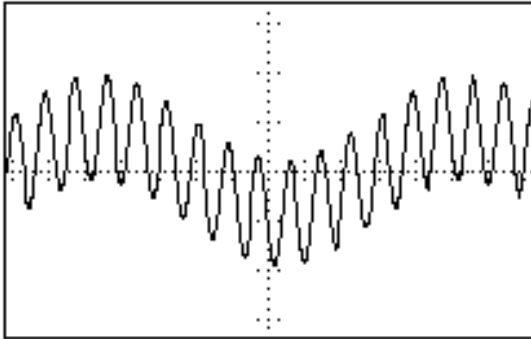

Figure 8. Wein Bridge notch filter.

2. Connect the oscilloscope and Function Generator as before. Set the Function Generator to produce a 10 Hz, 5 V_{pp} output. Note that the oscilloscope's autoscale feature may not work for low frequencies such as this.
3. **Slowly** scan the output frequency of the function generator while monitoring the output of the circuit on the oscilloscope (CH2). Determine the notch frequency of your filter. (60 Hz is the nominal frequency, but it is unlikely that your circuit will have its minimum output at exactly 60 Hz. Various versions that we have built operated with notch frequencies from 49 Hz to 78 Hz!)
4. Measure $V_{in,pp}$ and $V_{out,pp}$ at the frequencies listed in Data Table 5. You should modify the listed frequencies in the 40 Hz to 150 Hz range to get a good plot of the notch that your filter provides. Record your measurements in Data Table 5. You should determine appropriate frequencies to test in the mid-range depending on the notch frequency of your filter. The higher resolution of data points near the notch will give a better insight into the performance of the notch filter.
5. After determining the actual notch frequency of your circuit you will test its ability to remove "hum" from a circuit. The H-P Function Generators have been pre-programmed with some signals similar to those shown in figure 9. Determine the output of your notch filter for each of the following waveforms (see **Table 1**) from the arbitrary waveform menu of the Function Generator. Detailed instructions on how to select one of these waveforms on the function generator are given below. **Print the oscilloscope display which shows the input and output of your filter circuit for the ONE hum that the filter works best on.**

These have been chosen to be typical of the "hum" you might find at various locations around the world. Determine for which waveform your filter best removes the "hum." For only this waveform which best removes the "hum", print the oscilloscope display which shows the input and output of your filter circuit.

1. Press the *SHIFT* button on the H-P 33120A Function Generator.
2. Press the *ARB LIST* button.
3. Use the *RIGHT* or *LEFT* arrow keys to find
 $USHUM=60HZ+5HZ$
 $EUROHUM=50HZ+5HZ$
 $HILOHUM=70HZ+5HZ$
 $HIHUM=75HZ+5HZ$
4. Press *ENTER* to select one of the above arbitrary waveforms.
5. Set frequency to 5Hz
6. Set output level to 750 mV.



(a) Signal with 250 mV hum

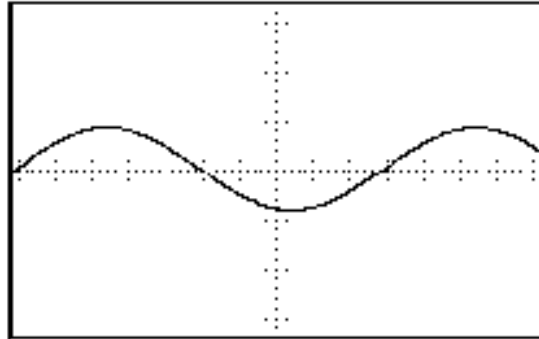

(b) Signal with hum removed

Figure 9. Example of effect of 60 Hz hum on 500 mV, 5 Hz signal. (USHUM)

EUROHUM	5 Hz signal + 50 Hz "hum"
USHUM	5 Hz signal + 60 Hz "hum"
HILOHUM	5 Hz signal + 70 Hz "hum"
HIHUM	5 Hz signal + 75 Hz "hum"

Table 1. Specifications for "Signal" + "hum" Waveforms

DATA AND REPORT SHEETS FOR LAB 12

Student Name (Print): _____ Student ID: _____

Student Signature: _____ Date: _____

Student Name (Print): _____ Student ID: _____

Student Signature: _____ Date: _____

Student Name (Print): _____ Student ID: _____

Student Signature: _____ Date: _____

Lab Group: _____

Data Table 1. Magnitude & Phase from Transfer Functions

	$ H(j\omega) $	$\angle H(j\omega)$
Band pass filter with op amp buffer (Figure 2.)	$\frac{\omega R_1 C_1}{\sqrt{[1 + (\omega R_1 C_1)^2][1 + (\omega R_2 C_2)^2]}}$	$Tan^{-1}\left(\frac{1 - \omega^2 R_1 C_1 R_2 C_2}{\omega R_1 C_1 + \omega R_2 C_2}\right)$
Active low pass filter (Figure 4.)	$\left(\frac{R_2}{R_1}\right) \frac{1}{\sqrt{1 + (\omega R_2 C)^2}}$	$Tan^{-1}(-\omega R_2 C)$

NOTE: We decided to give you this Data Table since they were tedious to derive.

Data Table 2. Buffered Band Pass Filter Characteristics

Frequency	V _{in}	V _{out}	20log ₁₀ H(jω)	Period	t1-t2	Δφ (deg)
100 Hz						
200						
300						
500						
1 kHz						
2						
4						
10						
20						
40						

70						
----	--	--	--	--	--	--

Data Table 3. First Order Low Pass Filter Characteristics

Frequency	V_{in}	V_{out}	$20\log_{10} H(j\omega) $	Period	t1-t2	$\Delta\phi$ (deg)
200						
500						
600						
700						
800						
900						
1.0 kHz						
1.1						
1.2						
1.3						
1.4						
1.5						
3						
5						
10						
50						

Data Table 4. Second Order Active Low Pass Filter Characteristics

Frequency	V_{in}	V_{out}	$20\log_{10} H(j\omega) $	Period	t1-t2	$\Delta\phi$ (deg)
200						
500						
600						
700						
800						
900						
1.0 kHz						
1.1						
1.2						
1.3						
1.4						
1.5						
3						
5						
10						
50						

Data Table 5. Notch Filter Characteristics

Frequency	V_{in}	V_{out}	$20\log_{10} H(j\omega) $
10 Hz			
25			
35			
40			
45			
55			
60			
70			
80			
100			
150			

Don't forget the Benchlink printout of your Notch filter performance!

Questions:

1. For the buffered bandpass filter (data in **Data Table 2**), plot both $20\log_{10}|H(j\omega)|$ (magnitude response) and $\Delta\phi(j\omega)$ (phase) as functions of $\log_{10}\omega$ on the two graphs below. You can use the graphs below for this. **IT IS RECCOMENDED THAT YOU MAKE THESE PLOTS ON A COMPUTER. Be sure to use the dB scale, and the units on the axes match up to the graphs provided for hand-plotting.** Determine the cutoff* frequencies from your plot and compare them with calculated values from equation (2).

$$\omega_{LO} \text{ (calculated)} = \underline{\hspace{2cm}} \quad \omega_{LO} \text{ (measured)} = \underline{\hspace{2cm}}$$

$$\omega_{HI} \text{ (calculated)} = \underline{\hspace{2cm}} \quad \omega_{HI} \text{ (measured)} = \underline{\hspace{2cm}}$$

Discuss the differences between your calculated and measured cutoff frequencies.

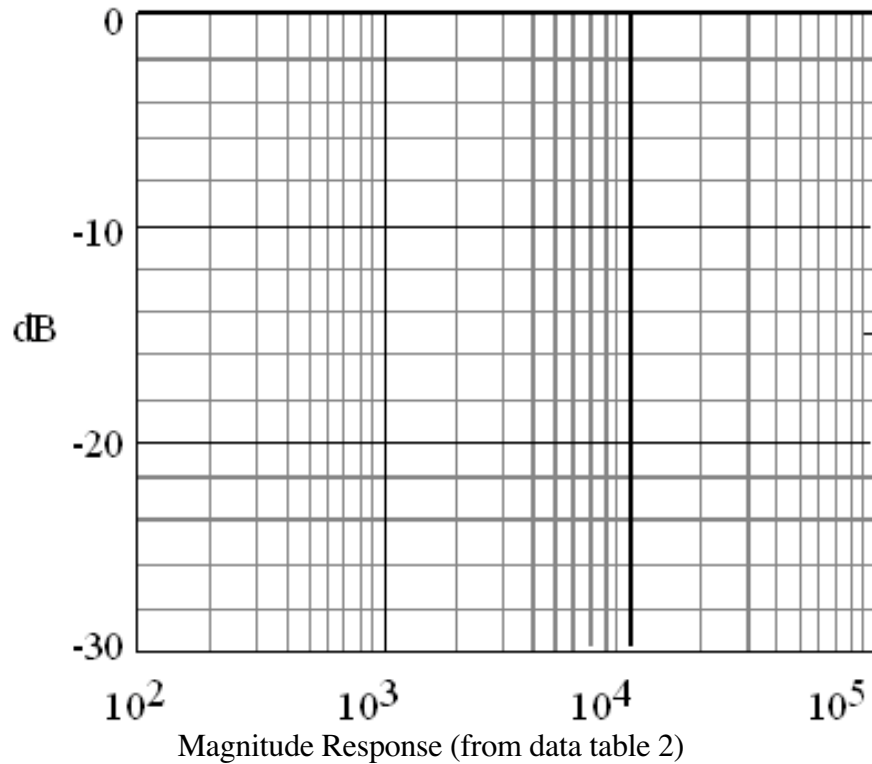

* NOTE: Remember from class that this is the frequency at which the magnitude of the frequency response drops to 0.707 of its maximum value. A low-pass or high pass filter has one cutoff frequency. A notch or bandpass filter has two cutoff frequencies. Break frequency is another term for cutoff frequency.

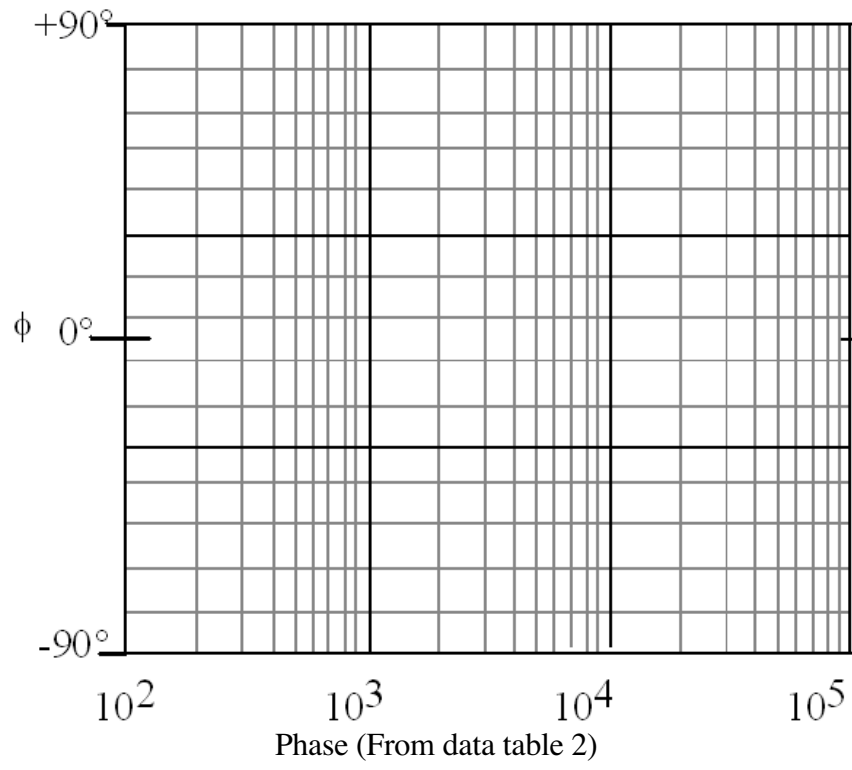

2. Plot your data for $\log_{10}|H(j\omega)|$ (magnitude response) and $\Delta\phi(j\omega)$ (Phase) for the first and second order active low pass filters as functions of $\log_{10}\omega$. Use the graphs provided below for this. **IT IS RECOMMENDED THAT YOU USE A COMPUTER FOR THESE PLOTS. Be sure to use the dB scale, and the units on the axes match up to the graphs provided for hand-plotting.** Be sure to denote which line corresponds to which filter. Draw best fit asymptotic (straight line) approximations for each of the two gain curves. This simply means that you should use a straight edge and draw a good fit to the passband and stop band parts of your frequency response curve. From your plots determine the cutoff frequencies and the slopes (this is also called the roll-off) for the two curves. Note that we are not interested in any slight slope in the passband; we are only interested in the slope in the stop band.

1st order low-pass:

$\omega_{\text{cutoff}} =$ _____ slope = _____ dB/decade

2nd order low-pass:

$\omega_{\text{cutoff}} =$ _____ slope = _____ dB/decade

Discuss the differences between the performance of the two filters:

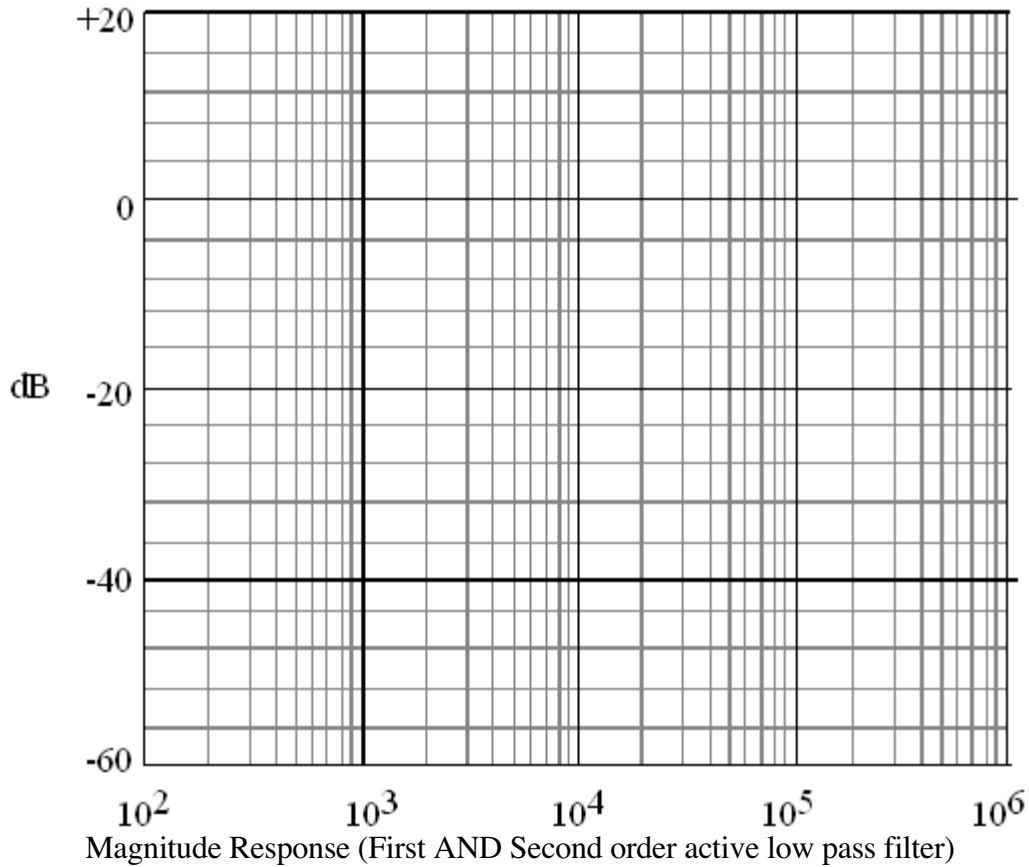

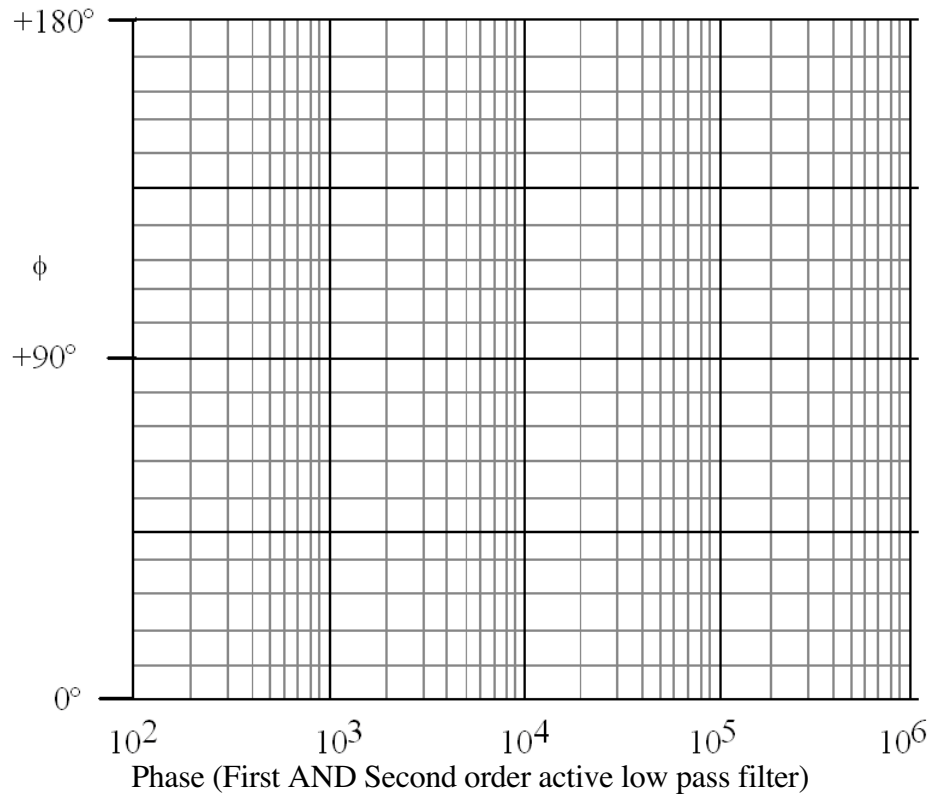

3. Plot $20\log_{10}|H(j\omega)|$ as a function of $\log_{10}\omega$ for the notch filter. Use the graph provided below for this.

What are the notch frequency and the maximum attenuation that you obtained with your circuit? The maximum attenuation would be the ratio of the output to input voltage computed at the notch frequency. Note that this should be computed in decibels.

$f_{\text{notch}} = \underline{\hspace{2cm}}$ Hz Max attenuation = $\underline{\hspace{2cm}}$ dB

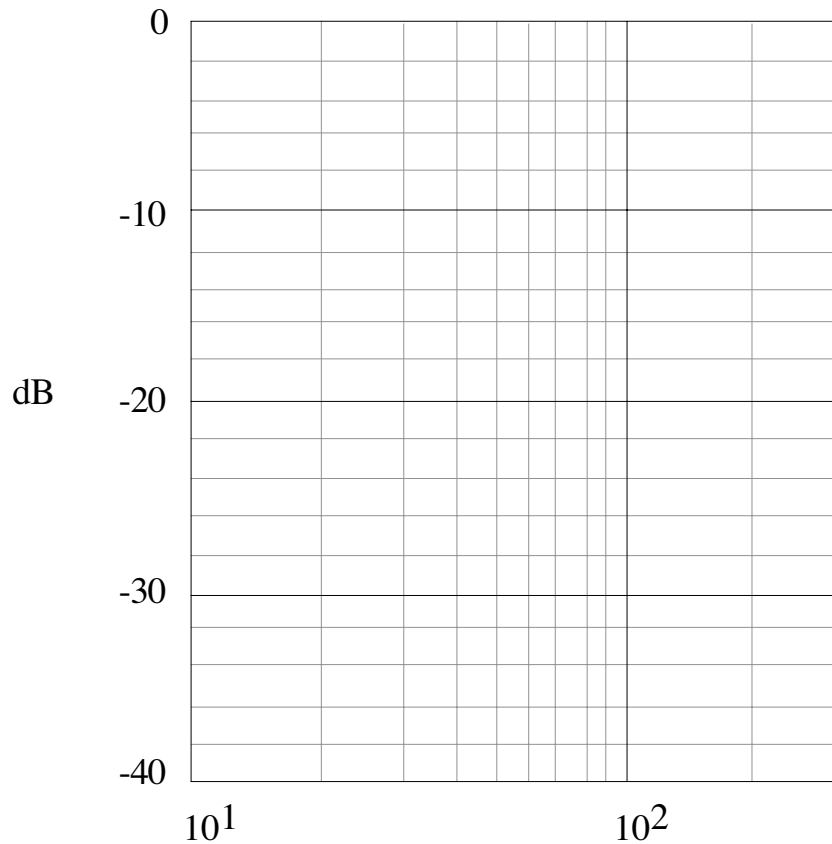

4. Recall the statement in part B that the inverting input of the op-amp introduces a 180° phase shift at the output in addition to the phase shift due to the filter. Explain what this statement means. (HINT: Compare the phase of your circuit to that of a passive low pass filter.) Does this change how you calculate the $\Delta\phi$ (deg) column in Data Table 3 and Data Table 4.