

CASE WESTERN RESERVE UNIVERSITY
 Case School of Engineering
 Department of Electrical Engineering and Computer Science
ENGR 210. Introduction to Circuits and Instruments (4)

Homework Set No. 7

References: [T&R4] sections 4-1, 4-2,4-4

Issued 2/23/05

Due 3/2/05

EQUIVALENT CIRCUITS WITH LINEAR DEPENDENT SOURCES

- 1) (5 pts) Norton equivalent with active sources.

Find the Norton equivalent circuit with respect to the terminals a,b for the circuit below.

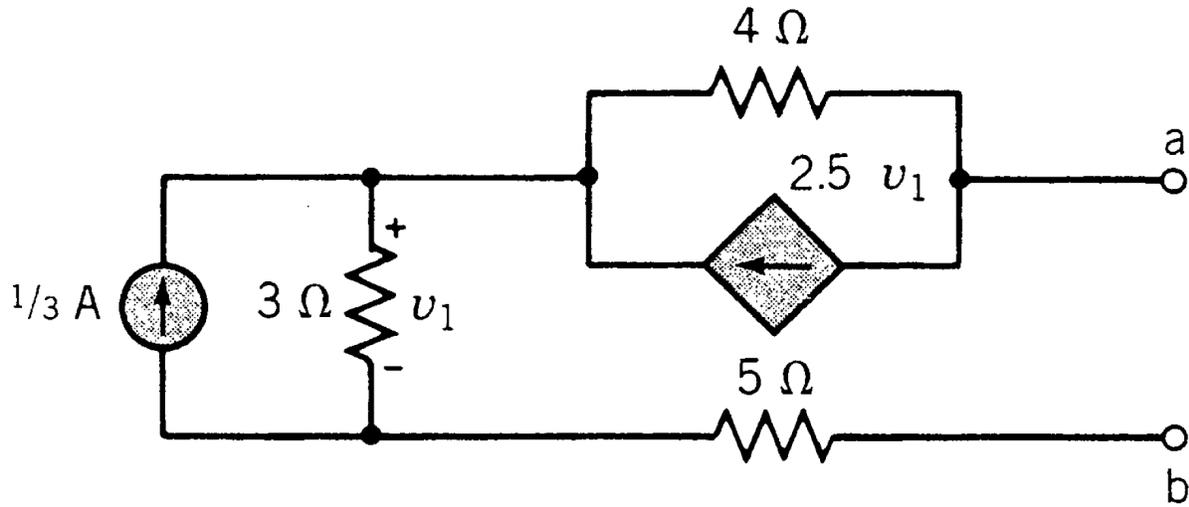

- 2) (5 pts) Thevenin equivalent with active sources, maximum power transfer.

- (a) Find the Thevenin equivalent of this circuit with respect to terminals a-b, i.e., if you remove R_L what is the Thevenin equivalent of this circuit at a-b?
- (b) The variable resistor (R_L) in the circuit below is adjusted for maximum power transfer to R_L . What is the numerical value of R_L ?
- (c) What is the maximum power in watts that can be transferred to R_L ?

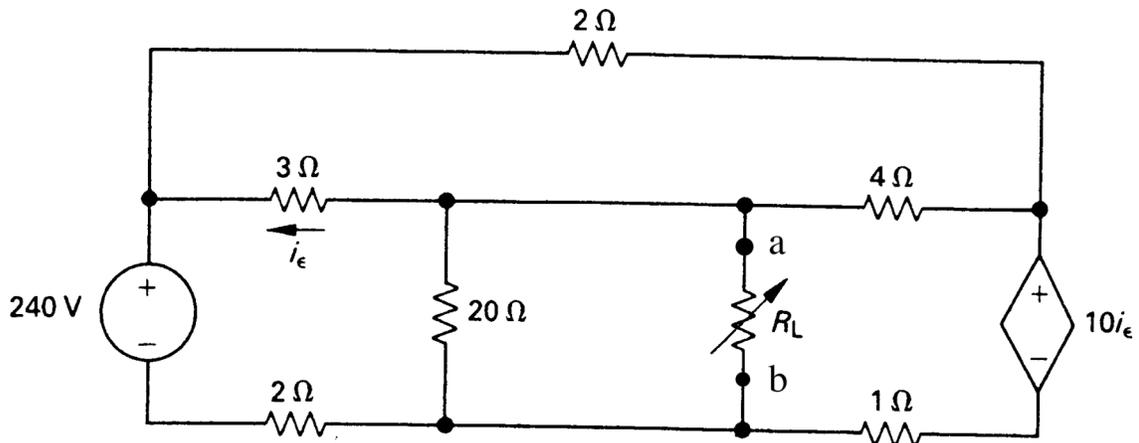

BASIC OP-AMP CIRCUITS

3) (5 pts) Inverting amplifier.

Find v_o in terms of v_s in the circuit below.

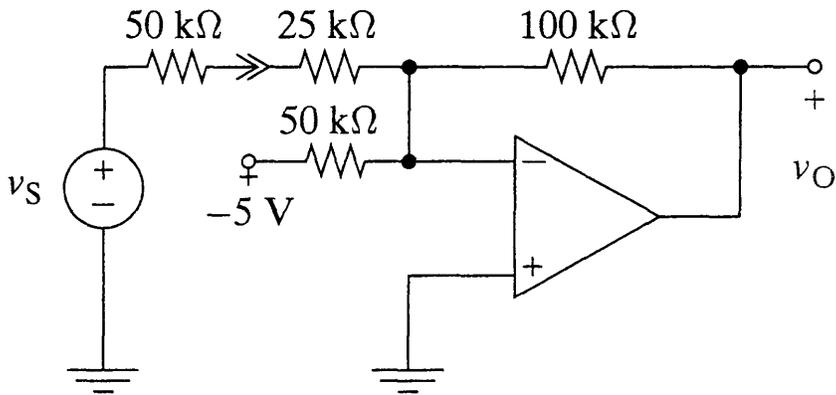

4) (5 pts) Difference amplifier

The circuit below is a voltage-subtracting circuit.

(a) Show that v_o can be expressed as
$$v_o = \frac{1 + \frac{R_2}{R_1}}{1 + \frac{R_3}{R_4}} v_2 - \frac{R_2}{R_1} v_1$$

(b) Design a circuit to give an output $v_o = 4v_2 - 11v_1$.

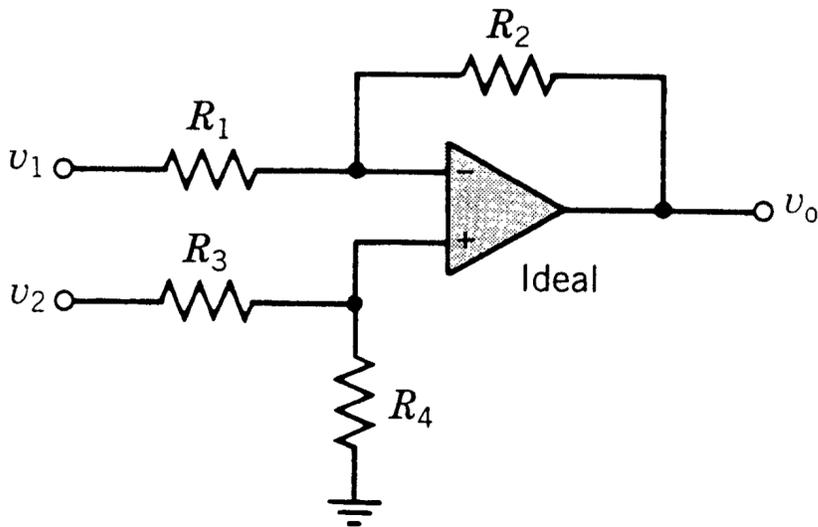

5) (5 pts) Non-inverting amplifier

(a) Find v_o in terms of v_s .

(b) Find i_o for $v_s=1.5$ volts.

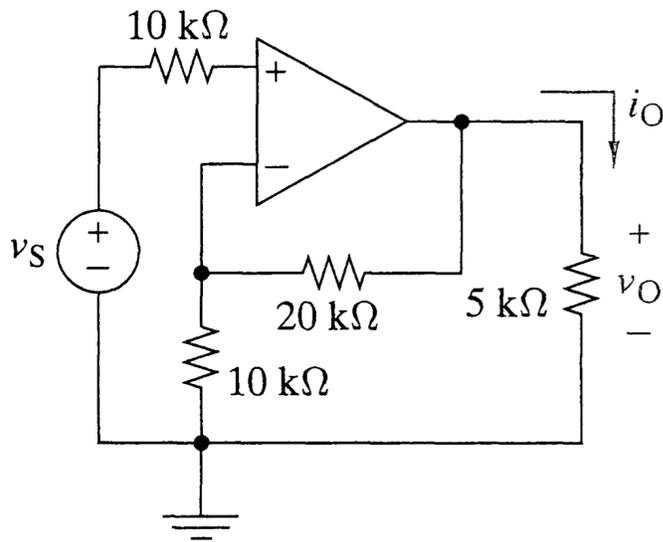

NOTE: Please put section code AND your CWRU e-mail next to name at top of page. Section codes are

- MA (Monday Afternoon)
- ME (Monday Evening)
- TA (Tuesday Afternoon)
- TE (Tuesday Evening)
- WA (Wednesday Afternoon)
- WE (Wednesday Evening)