

Chapter 7 - First- and Second- Order Circuits

7-1 RC and RL Circuits

Linear Circuit

use device and connection equations to write differential equation describing the circuit

Differential Equation

solve differential equation

Classical Techniques

use classical techniques for solving D.E. (other techniques include phasors & Laplace transform)

Response Waveform

RC and RL Equations

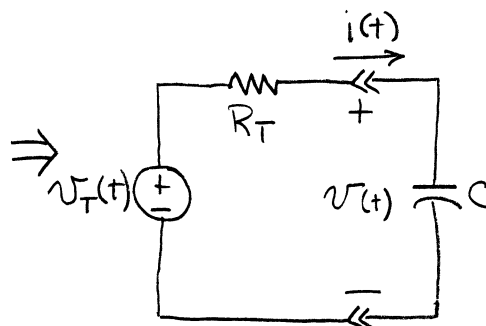
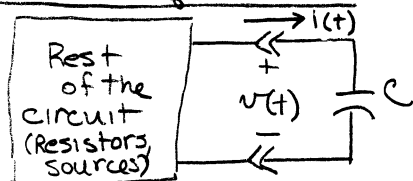

Doing KVL gives

$$-v_T(t) + i(t)R_T + v(t) = 0$$

From the previous chapter the capacitor is described by

$$i(t) = C \frac{dv(t)}{dt}$$

Substituting

$$-v_T(t) + C \frac{dv(t)}{dt} R_T + v(t) = 0$$

Re-arranging

first order linear differential equation with constant coefficients

$$R_T C \frac{dv(t)}{dt} + v(t) = v_T(t)$$

$v_T(t)$ is the input and $v(t)$ is the response

$v(t)$ is called the state variable and determines the amount of energy stored in the RC circuit.

We can do the same with an inductor.

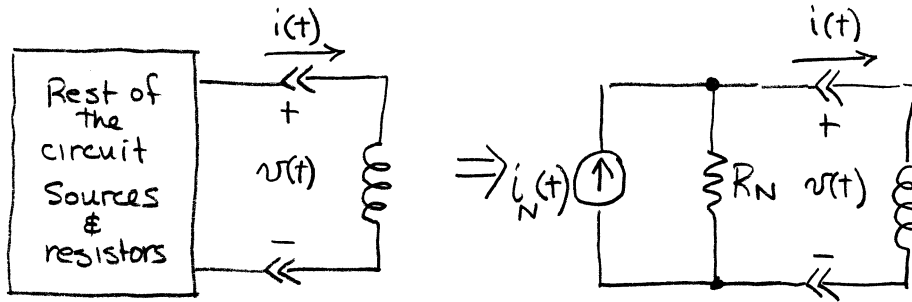

Using KCL at the node gives $\sum_{+in} i = 0$

$$+i_N(t) - \frac{v(t)}{R_N} - i(t) = 0$$

The element constraint is $v(t) = L \frac{di(t)}{dt}$

Substituting

$$i_N(t) - \frac{L}{R_N} \frac{di(t)}{dt} - i(t) = 0$$

Re-arranging

$$\frac{L}{R_N} \frac{di(t)}{dt} + i(t) = i_N(t)$$

- first-order linear differential equation with constant coefficients
- $i_N(t)$ is the forcing function
- $i(t)$ is the state variable as it defines the amount of energy stored in the RL circuit

Any circuit containing a single capacitor or inductor and resistors is a first-order circuit described by a first-order differential equation.

7-2 First Order Circuit Step Response

Consider the following circuit

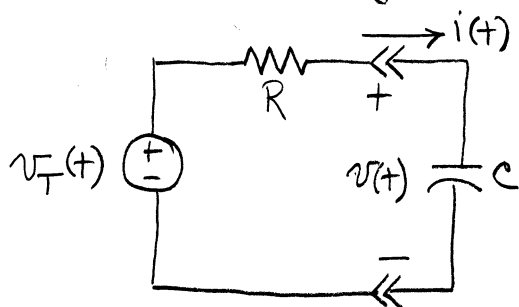

We solved this circuit previously for $v_T(t) = 0$, $t \geq 0$

Consider the case where $v_T(t) = V_A u(t)$

The circuit differential equation is

$$R_T C \frac{dv}{dt} + v = V_A u(t)$$

$$\text{or } R_T C \frac{dv}{dt} + v = V_A \text{ for } t \geq 0$$

While there are many methods to solve this equation we will use superposition.

$$v(t) = \underbrace{v_N(t)}_{\text{natural response}} + \underbrace{v_F(t)}_{\text{forced response}}$$

natural response
when input is
set to zero.

forced response
to the input
step function

Natural response:

$$R_T C \frac{dv_N}{dt} + v_N = 0$$

$$\text{Solution is } v_N(t) = K e^{-\frac{t}{R_T C}} \quad t \geq 0$$

which we have seen previously.

7-4 First-order Circuit Sinusoidal Response

In previous sections we determined that the solution of a linear first-order differential equation consisted of a forced and natural response. We determined the response to a step-input. In this section we consider the response to a causal sinusoid, $V_A \cos \omega t u(t)$.

The complete differential equation for a first order RC circuit is

$$R_T C \frac{dv(t)}{dt} + v(t) = V_A \cos \omega t u(t)$$

The natural response does not change and is given by

$$v_N(t) = K e^{-\frac{t}{R_T C}} \quad t \geq 0$$

The forced response is a solution of

$$R_T C \frac{dv_F(t)}{dt} + v_F(t) = V_A \cos \omega t \quad t \geq 0$$

The only solution of this equation is another sinusoid.

Consider $v_F(t) = a \cos \omega t + b \sin \omega t$

This is called the method of undetermined coefficients.

$$R_T C \frac{d}{dt}(a \cos \omega t + b \sin \omega t) + (a \cos \omega t + b \sin \omega t) = V_A \cos \omega t$$

$$R_T C (-a \omega \sin \omega t + b \omega \cos \omega t) + (a \cos \omega t + b \sin \omega t) = V_A \cos \omega t$$

$$[-a \omega R_T C + b] \sin \omega t + [b \omega R_T C + a - V_A] \cos \omega t = 0$$

This is only true when the sine and cosine coefficients are identically zero.

$$a + (R_T C \omega) b = V_A$$

$$(-\omega R_T C) a + b = 0$$

$$a + \omega R_T C b = V_A$$

$$-(\omega R_T C)^2 a + (\omega R_T C) b = 0$$

subtracting $1 + (\omega R_T C)^2 a = V_A$

$$a = \frac{V_A}{1 + (\omega R_T C)^2}$$

Substituting $b = (\omega R_T C) a = \frac{\omega R_T C V_A}{1 + (\omega R_T C)^2}$

The forced response is then

$$v_F(t) = \frac{V_A}{1 + (\omega R_T C)^2} [\cos \omega t + \omega R_T C \sin \omega t] \quad t \geq 0$$

The total solution is then

$$v(t) = K e^{-\frac{t}{R_T C}} + \frac{V_A}{1 + (\omega R_T C)^2} [\cos \omega t + \omega R_T C \sin \omega t] \quad t \geq 0$$

The initial condition $v_0(t=0) = V_0$ requires

$$v(0) = K e^0 + \frac{V_A}{1 + (\omega R_T C)^2} [1 + 0] = V_0$$

$$\therefore K = V_0 - \frac{V_A}{1 + (\omega R_T C)^2}$$

The total solution is then

$$v(t) = \underbrace{\left[V_0 - \frac{V_A}{1 + (\omega R_T C)^2} \right] e^{-\frac{t}{R_T C}}}_{\text{natural response}} + \underbrace{\frac{V_A}{1 + (\omega R_T C)^2} [\cos \omega t + \omega R_T C \sin \omega t]}_{\text{forced response}} \quad t \geq 0$$

The more commonly used form of the solution requires converting the second term to magnitude and phase format.

$$v(t) = \underbrace{\left[V_0 - \frac{V_A}{1 + (\omega R_T C)^2} \right] e^{-\frac{t}{R_T C}}}_{\text{natural response}} + \underbrace{\frac{V_A}{\sqrt{1 + (\omega R_T C)^2}} \cos(\omega t + \theta)}_{\text{forced response}^*} \quad t \geq 0$$

where we used

$$\cos \omega t + \omega R_T C \sin \omega t = \sqrt{1 + (\omega R_T C)^2} \cos(\omega t + \theta)$$

$$\theta = \tan^{-1} \left(\frac{-\omega R_T C}{1} \right) = \tan^{-1}(-\omega R_T C)$$

Observations:

1. The forced sinusoidal response lasts whereas the natural response decays to zero.
2. The forced sinusoidal response is of the same frequency (ω) as the input but with a different magnitude and phase
3. The forced response is proportional to V_A .

* the forced response is called
 the sinusoidal steady-state response
 the ac steady-state response
 the ac response

Technically we have found the solution to the step-function

$$V_A [\cos \omega t] u(t)$$

If $\omega = 0$ this reduces to the previous solution for

$$V_A u(t)$$

Example 7-12

The switch in the figure below has been open for a long time and is closed at $t=0$. Find the voltage $v(t)$ for $t \geq 0$ when $v_s(t) = 20 \sin 1000t \text{ u}(t)$

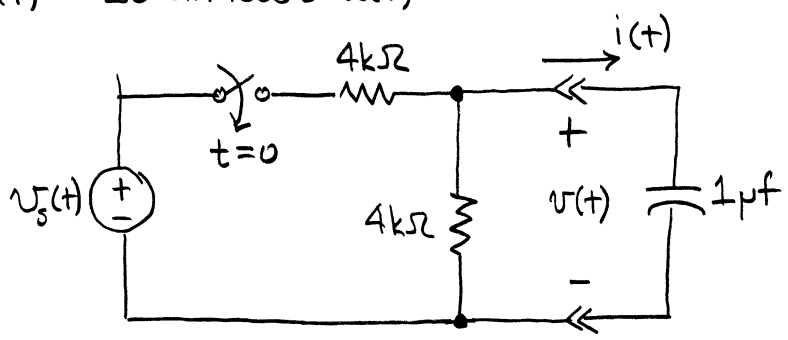

We have to derive the circuit differential equation by Thevenizing the circuit.

Shorting $v_s(t)$, $R_T = 4k \parallel 4k = 2k\Omega$

$$v_T(t) = \frac{4k}{4k+4k} v_s(t) = 10 \sin 1000t \text{ u}(t)$$

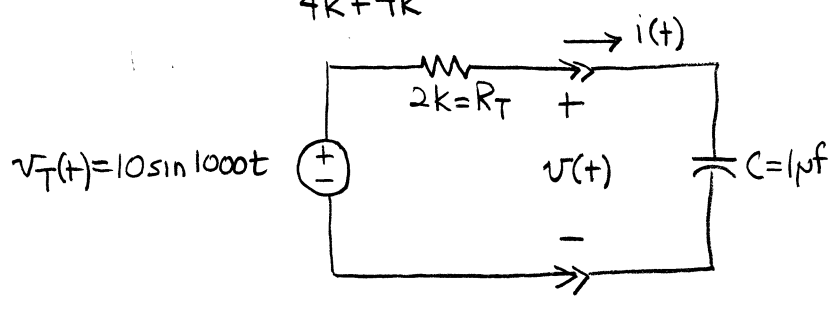

$$R_T C = (2 \times 10^3)(1 \times 10^{-6}) = 2 \times 10^{-3}$$

$$-v_T(t) + i(t)R_T + v(t) = 0$$

$$\uparrow$$

$$i(t) = C \frac{dv}{dt}$$

$$R_T C \frac{dv}{dt} + v(t) = v_T(t)$$

$$(2 \times 10^{-3}) \frac{dv(t)}{dt} + v(t) = 10 \sin 1000t$$

Now we can compute the natural and forced responses.

$$v_N(t) = Ke^{-\frac{t}{R_T C}} \quad t \geq 0$$

Using undetermined Fourier coefficients we write

$$v_F(t) = a \cos 1000t + b \sin 1000t$$

We substitute $v_F(t)$ into the differential equation

$$(2 \times 10^{-3}) \frac{d}{dt} (a \cos 1000t + b \sin 1000t) + (a \cos 1000t + b \sin 1000t) = 10 \sin 1000t$$

$$\frac{1}{500} [-a 1000 \sin 1000t + b 1000 \cos 1000t] + [a \cos 1000t + b \sin 1000t] = 10 \sin 1000t$$

$$[-a + b - 10] \sin \omega t + [b + a] \cos \omega t = 0$$

$$a + 2b = 0$$

$$-2a + b = 10$$

$$2a + 4b = 0$$

$$-2a + b = 10$$

$$5b = 10 \Rightarrow b = 2$$

$$a = -2b = -2(2) = -4$$

$$\therefore v(t) = v_N(t) + v_F(t)$$

$$v(t) = K e^{-\frac{t}{.002}} - 4 \cos 1000t + 2 \sin 1000t$$

K is found from the initial condition that $v(0) = 0$ since the switch was open for a long time the capacitor is uncharged.

$$\therefore v(0) = 0 = K e^0 - 4 + 0 \Rightarrow K = 4$$

The complete response is

$$v(t) = 4 e^{-\frac{t}{.002}} - 4 \cos 1000t + 2 \sin 1000t$$

In magnitude and phase

$$v(t) = 4 e^{-\frac{t}{.002}} + \sqrt{(4)^2 + (2)^2} \cos(1000t + \tan^{-1}(\frac{2}{4}))$$

$$v(t) = 4 e^{-\frac{t}{.002}} + 4.472 \cos(1000t + 26.5^\circ)$$

Example 7-13

Find the sinusoidal steady-state response of the output voltage $v_o(t)$ in the circuit shown below. when the input current is

$$i_s(t) = [I_A \cos \omega t] u(t)$$

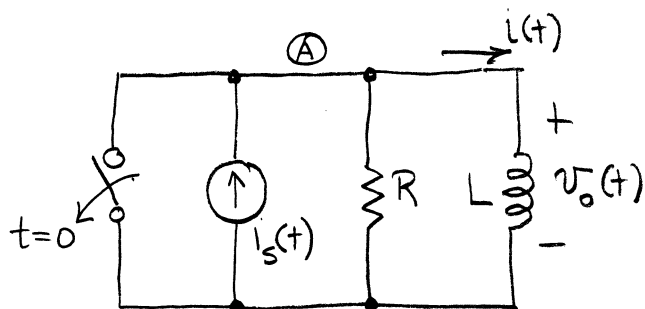

The switch guarantees that $i(t < 0) = 0$

For $t > 0$ using KCL @ A $\sum_{+in} i = 0$

$$+i_s(t) - \frac{v_o(t)}{R} - i(t) = 0$$

Using the inductor constraint $v_o(t) = L \frac{di}{dt}$

$$-\frac{L}{R} \frac{di(t)}{dt} - i(t) + i_s(t) = 0$$

$$\frac{L}{R} \frac{di(t)}{dt} + i(t) = i_s(t) = I_A \cos \omega t \quad t \geq 0$$

We are only asked to find the forced component

Using the method of undetermined coefficients we write

$$i_F(t) = a \cos \omega t + b \sin \omega t$$

Substituting this into the differential equation gives

$$\frac{L}{R} \frac{d}{dt} [a \cos \omega t + b \sin \omega t] + [a \cos \omega t + b \sin \omega t] = I_A \cos \omega t$$

$$-\frac{L}{R} a \omega \sin \omega t + \frac{L}{R} b \omega \cos \omega t + a \cos \omega t + b \sin \omega t = I_A \cos \omega t$$

Collecting like terms

$$\left[-\frac{L}{R} a \omega + b \right] \sin \omega t + \left[\frac{L}{R} b \omega + a - I_A \right] \cos \omega t = 0$$

We require

$$-\frac{L}{R}\omega a + b = 0$$

$$a + \frac{L}{R}\omega b = I_A$$

$$+\frac{L}{R}\omega a + \left(\frac{L}{R}\omega\right)^2 b = \left(\frac{L}{R}\omega\right) I_A$$

$$\left[1 + \left(\frac{L}{R}\omega\right)^2\right] b = \left(\frac{L}{R}\omega\right) I_A$$

$$b = \frac{\left(\frac{L}{R}\omega\right) I_A}{1 + \left(\frac{L}{R}\omega\right)^2}$$

$$a = \frac{b}{\left(\frac{L}{R}\omega\right)} = \frac{I_A}{1 + \left(\frac{L}{R}\omega\right)^2}$$

The forced component is then

$$i_F(t) = \frac{I_A}{1 + \left(\frac{L}{R}\omega\right)^2} \cos \omega t + \frac{\left(\frac{L}{R}\omega\right) I_A}{1 + \left(\frac{L}{R}\omega\right)^2} \sin \omega t$$

The output voltage $v_o(t) = L \frac{di_F(t)}{dt}$

$$v_o(t) = L \frac{d}{dt} \left[\frac{I_A}{1 + \left(\frac{L}{R}\omega\right)^2} \cos \omega t + \frac{\left(\frac{L}{R}\omega\right) I_A \sin \omega t}{1 + \left(\frac{L}{R}\omega\right)^2} \right]$$

$$v_o(t) = \frac{-L I_A \omega}{1 + \left(\frac{L}{R}\omega\right)^2} \sin \omega t + \frac{L^2 \omega^2 I_A \cos \omega t}{R \left[1 + \left(\frac{L}{R}\omega\right)^2\right]}$$

$$v_o(t) = \frac{I_A \omega L}{1 + \left(\frac{L}{R}\omega\right)^2} \left[-\sin \omega t + \omega \frac{L}{R} \cos \omega t \right]$$

$$v_o(t) = \frac{I_A \omega L}{1 + \left(\frac{L}{R}\omega\right)^2} \sqrt{1 + \left(\omega \frac{L}{R}\right)^2} \cos \left(\omega t + \tan^{-1} \left(+\omega \frac{L}{R} \right) \right)$$

$$v_o(t) = \frac{I_A \omega L}{\sqrt{1 + \left(\frac{L}{R}\omega\right)^2}} \cos\left(\omega t + \tan^{-1}\left(\frac{L}{R}\omega\right)\right)$$

amplitude
changes
with the
frequency of
the sinusoidal
input

At dc ($\omega=0$) the amplitude goes to zero since the inductor acts like a short.

As $\omega \rightarrow \infty$ the amplitude goes to $\frac{I_A \omega L}{\frac{L}{R}\omega} = I_A R$

which makes sense since the inductor acts like an open forcing all current through the resistor

This is a frequency dependent response. ■

The forced sinusoid remaining after the natural component disappears is called the sinusoidal steady-state response.

8-1 Sinusoids and Phasors

The fundamental relationship between sinewaves and complex numbers comes from Euler's identity

$$e^{j\theta} = \cos\theta + j\sin\theta$$

Define $\cos\theta = \text{Re}\{e^{j\theta}\}$ ← we use the cosine to describe the eternal sinewave

$$\sin\theta = \text{Im}\{e^{j\theta}\}$$

Expanding upon the general sinusoid

$$v(t) = V_A \cos(\omega t + \phi)$$

$$v(t) = V_A \text{Re}\{e^{j(\omega t + \phi)}\} = \text{Re}\{(V_A e^{j\phi}) e^{j\omega t}\}$$

this is defined to be the phasor representation of the sinusoid $v(t)$

$$\underline{V} \triangleq V_A e^{j\phi} = V_A \cos\phi + j V_A \sin\phi$$

↑
the phasor \underline{V} is a complex number

1. Phasors will be written with an underline (\underline{V}) to distinguish them from signal waveforms such as $v(t)$,

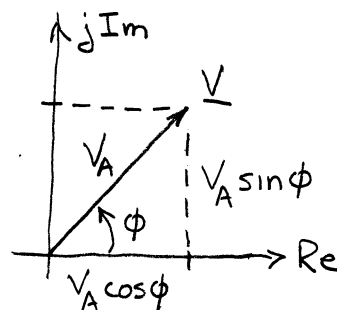

2. A phasor is determined by amplitude and phase angle and does not contain any information about the frequency.

