

ENGR 210 Lab 6

Thevenin Equivalent Circuits

BACKGROUND

As discussed in class when we connect a load across two terminals of a circuit, that load experiences a specific voltage and current that is a function of the resistance (impedance) of the load and the characteristics of the circuit to which the load is connected. Thevenin's theorem tells us that any linear circuit will have a voltage/current relationship for a load that is the same as that of a simple one source, one resistor (impedance) circuit. For example. Figures 1-(a) and 1-(b) show two circuits, each connected to a load resistor R_L .

Step 1: For the circuits of figures 1-(a) and 1-(b). calculate the voltage, current and power that will be supplied to the load resistor for a load resistor value of $R_L = 100 \Omega$.

Step 2: For each of circuits 1-(a) and 1-(b). calculate the voltage, current and power that will be supplied to the load resistor for a load resistor value of $R_L = 50 \Omega$ and $R_L = 500 \Omega$.

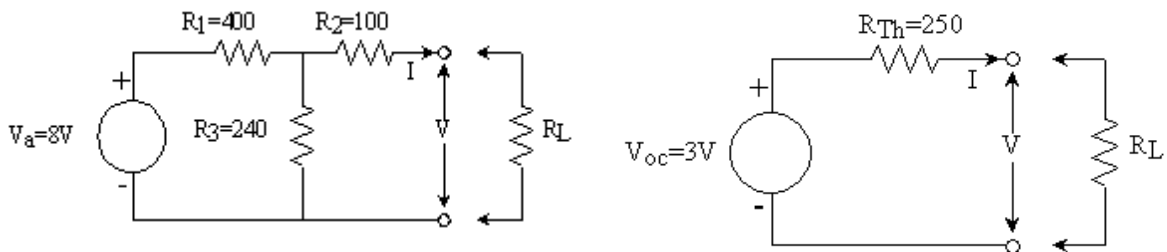

Figure 1: Two circuits with the same voltage/current relationship at terminals A-B.

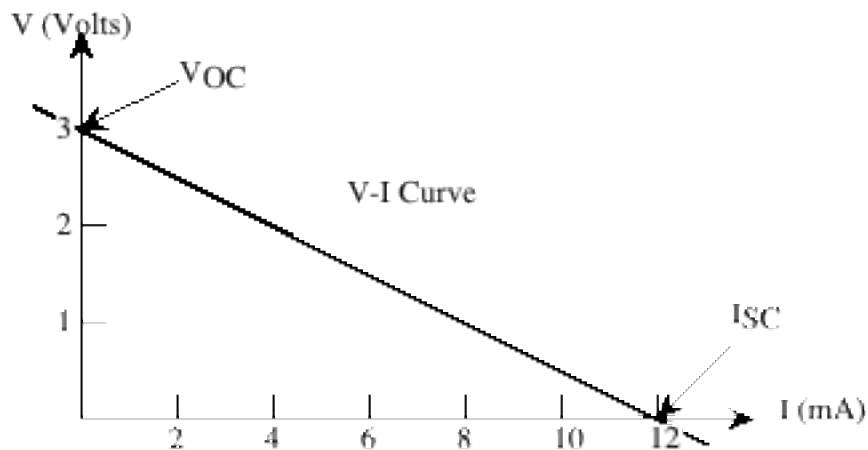

Figure 2: The (V-I) curve of circuits 1-(a) and 1-(b).

The basis for the fact that R_L experiences the same voltage, current and power dissipation in the two circuits is the fact that circuits 1-(a) and 1-(b) have the same voltage/current

relationship at terminals A and B. This relationship is plotted in figure 2. For either circuit, if there is a certain current flowing between the terminals, there will be a certain corresponding voltage at the terminals, determined by the circuit elements. For any linear circuit, the relationship will be a linear one, i.e, a line such as is plotted in figure 2. Any linear circuit will give a line; but for the Thevenin equivalent circuit the connection between the circuit and the line is particularly simple: the voltage axis intercept is V_{oc} , and the slope of the line (volts/amp) is given by the Thevenin equivalent resistance, R_{Th}

The load itself imposes another (V-I) relationship, as shown by the load lines in figure 3; and the specific value of voltage and current corresponds to the intercept of the load lines and the (V-I) curve of the circuit, as shown in figure 3. Plotting a (V-I) curve and the load lines, and finding the intercept is a general method to find circuit operating points. The method works even for non-linear circuits.

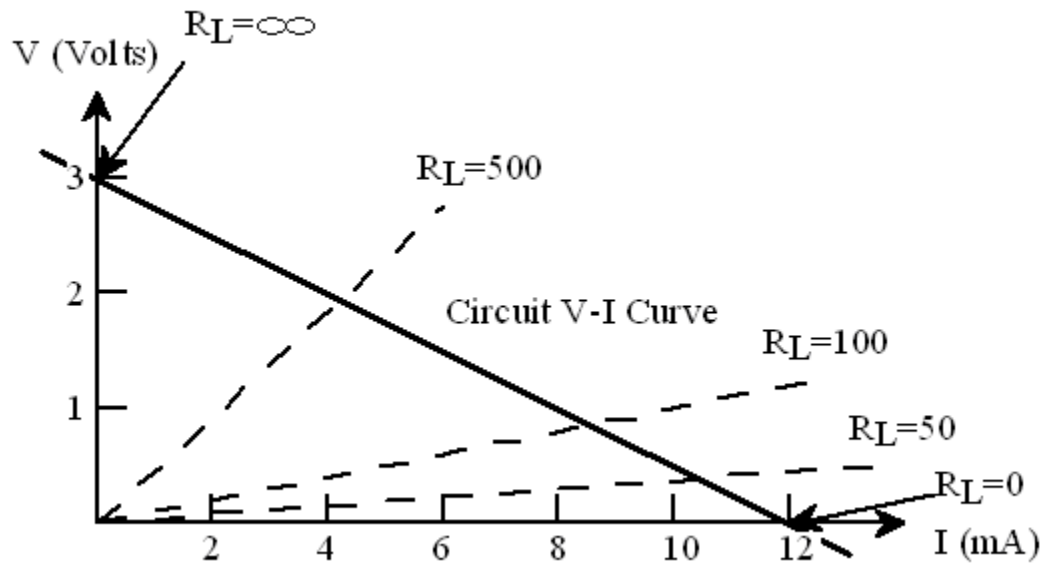

Figure 3: The (V-I) curve of circuits 1-(a) and 1-(b) with 50 Ω , 100 Ω and 500 Ω load lines plotted as dashed lines.

Every terminal pair in a linear circuit has a Thevenin equivalent circuit. If a load is connected at terminals A-B in the circuit of figure 4, for example, it sees a different equivalent voltage and resistance from that which it would see connected at terminals C-D, as shown in figure 6.

LABORATORY

Caution

When modifying a circuit, ALWAYS turn off the power. Take measurements carefully: avoid making short circuits with the probes or touching electrical contacts directly with fingers.

IMPORTANT: Question 7 needs to be answered to perform step 7.

PART I. Measuring the parameters of a Thevenin Equivalent Circuit

Step 1: Build the circuit shown in figure 4. For the two power supplies use the HP ES3631A in the lab. Be careful in how you connect the supplies—the black common terminal from the HP should go to the common connection labeled D in the circuit in figure 4. The specified resistors are available from the drawers in the back of Glennan 308.

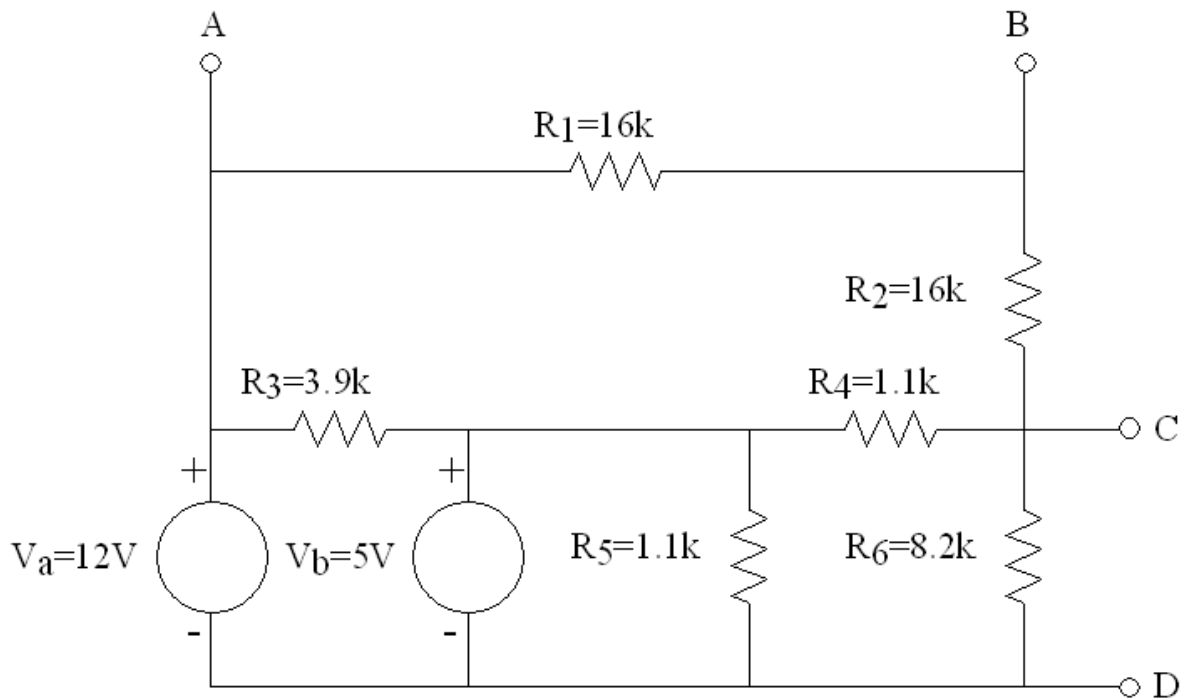

Figure 4: A circuit with two possible output connection points.

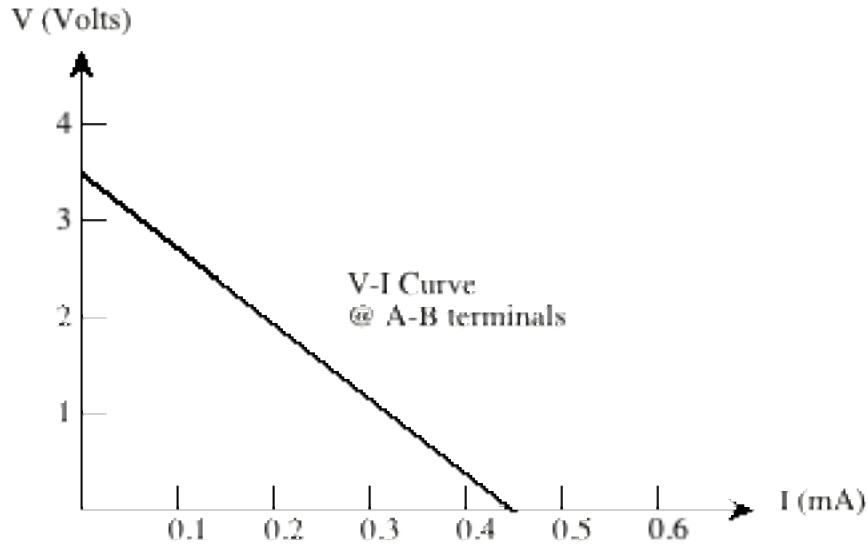

Figure 5: The (V-I) curve of the A-B terminal pair in the circuit of figure 4.

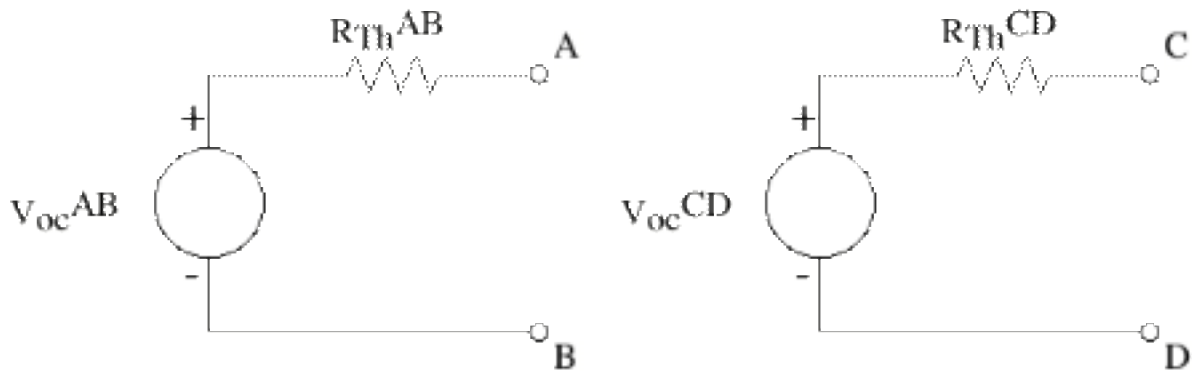

Figure 6: Two Thevenin equivalent circuits.

Step 2: Determine the Thevenin equivalent circuit at connection points A-B and at connection points C-D by direct measurement. To do this:

- A. Measure V_{oc} , the open circuit voltage across each of the connection point pairs. Record these values in Data Table 1
- B. Measure R_{Th} by disconnecting BOTH power supplies from the circuit and replacing them with short circuits. With the circuit in this configuration, measure the resistance across each terminal pair with the DMM. Record these values in Data Table 1

Step 3: Reconnect the power supplies and use the ammeter of your DMM to measure the short circuit current I_{sc} for terminals A-B. To measure short circuit current between two points use the ammeter (negligible resistance) to connect the two nodes being shorted. Be sure to remove all shorting wires from step 2 and make sure that power is not directly connected to ground. Record your data in Data Table 2

Step 4: Repeat step 3 to determine I_{sc} for terminals C-D. Once again, make sure that power is not connected to ground. Record your data in Data Table 2

Step 5: One at a time, connect load resistors to terminal pair (A-B) as shown in figure 7. Use load resistors of $51\ \Omega$, $180\ \Omega$, $1.1\ k\Omega$ and $3.9\ k\Omega$. Record the circuit output voltage. The circuit output voltage is the voltage across the load resistor, for each of the four load resistor values in Data Table 3.

Step 6: One at a time, connect load resistors to terminal pair (C-D) as shown in figure 7. Use load resistors of $51\ \Omega$, $180\ \Omega$, $1.1\ k\Omega$ and $3.9\ k\Omega$. Record the circuit output voltage. The circuit output voltage is the voltage across the load resistor, for each of the four load resistor values in Data Table 4.

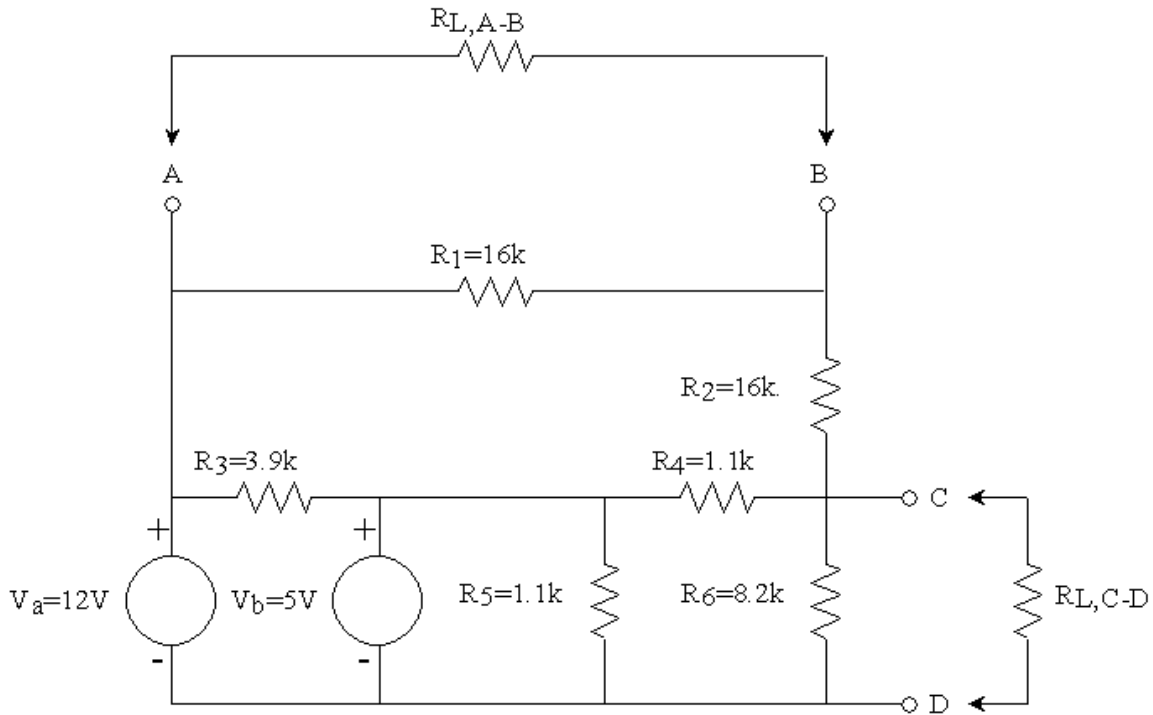

Figure 7: Terminal pair A-B loaded.

Step 7: Connect the combination of load resistors determined in question 10 (in the question section at the end of the lab) to terminals A-B, and measure the resulting load voltage. Record your resulting voltage in Data Table 5

Step 8: Turn off all power sources and take circuit apart. Be sure to return the resistors to the APPROPRIATE bin.

DATA SHEET FOR LAB 6

Student Name (Print): _____ Student ID (e-mail): _____

Student Signature: _____ Date: _____

Student Name (Print): _____ Student ID (e-mail): _____

Student Signature: _____ Date: _____

Student Name (Print): _____ Student ID (e-mail): _____

Student Signature: _____ Date: _____

Lab Group: _____ Lab Time: _____

Data Table 1. Open Circuit Voltage Measurements

Measurement	Measured Value	Calculated Voltage	% Difference
V _{A-B} (open circuit)			
V _{C-D} (open circuit)			
R _{A-B} (power supplies disconnected and shorted)			
R _{C-D} (power supplies disconnected and shorted)			

Data Table 2. Short Circuit Circuit Measurements

Measurement	Measured Current	Calculated Current	% Difference
I _{sc,A-B} (short circuit)			
I _{sc,C-D} (open circuit)			

Data Table 3. Load Resistor Measurements (Terminals A-B)

Load Resistance	Measured Voltage	Calculated Value	% Difference
51 Ω			
180 Ω			
1.1 kΩ			
3.9 kΩ			

Data Table 4. Load Resistor Measurements (Terminals C-D)

Load Resistance	Measured Voltage	Calculated Value	% Difference
51 Ω			
180 Ω			
1.1 k Ω			
3.9 k Ω			

Data Table 5. Measured voltage for 1.5 volt output design R_L : _____

WRITE-UP AND EXERCISES

1. In figure 5 the (V-I) curve of the A-B terminal pair is shown. Verify by analysis that this is the A-B (V-I) curve and determine the Thevenin equivalent circuit for terminal pair A-B.
2. Determine and plot the (V-I) curve for terminal pair C-D in figure 4. Draw the Thevenin equivalent circuit for terminal pair C-D.
3. Calculate the short circuit current, I_{sc} , for each of the two terminal pairs, and on one graph show the (V-I) curve (the line from V_{oc} to I_{sc} on the (V-I) plane) for each of the terminal pairs.
4. Do your calculated short circuit currents agree with your measurements? What accounts for your error?
5. Using Ohm's law, calculate the current corresponding to each load resistor voltage measured in step 5 at terminal pair (A-B). Plot the load resistor (V-I) points, i.e., the load resistor voltages and currents, on the (V-I) curve plotted for terminals A-B in Question 2. Is there good agreement?
6. Using Ohm's law, calculate the current corresponding to each load resistor voltage measured in step 6 at terminal pair (C-D). Plot the load resistor (V-I) points, the load resistor voltages and currents, on the (V-I) curve plotted for terminals C-D in question 2. Is there good agreement?
7. (ANALYSIS) To which terminal pair (A-B or C-D) should an $18\text{ K}\Omega$ resistor be connected so that it dissipates the most power? To which terminal pair should a $470\ \Omega$ resistor be connected so that it dissipates the most power?
8. (DESIGN): Suppose that a voltage of 1.5 volts is required at terminals A-B. What resistance load resistor would have to be connected to terminals A-B to get 1.5 volts?
BE SURE TO SHOW YOUR CALCULATIONS FOR ANY DESIGN.
9. Is it easier to make this calculation using the original circuit schematic or the Thevenin equivalent?
10. Given that the resistors available are:
 $51\ \Omega$, $180\ \Omega$, $750\ \Omega$, $1.1\text{ k}\Omega$, $3.9\text{ k}\Omega$, $8.2\text{ k}\Omega$
what combination of resistors give (approximately) the required resistance determined in question 8? Given that the resistor tolerance is $\pm 5\%$, is the approximation reasonable?
11. Did your voltage for the constructed load agree well with the desired voltage of 1.5 volts?