

Reading Assignment.

Ch. 1 - Inan & Inan. Review of much of what we have already done.

Ch. 2. 2.1, 2.2 For this week.

2.3 if you want to get ahead.

2.1 The wave equation can be derived directly from Maxwell's Equations in differential form. We will assume that the media is unbounded, simple, source-free and lossless.

$$\nabla \times \underline{E} = - \frac{\partial \underline{B}}{\partial t} \quad (1)$$

$$\nabla \cdot \underline{D} = \tilde{\rho}$$

Note: Inan ⁽²⁾ uses this notation to avoid confusion with phasor ρ later on.

$$\nabla \times \underline{H} = \underline{J} + \frac{\partial \underline{D}}{\partial t} \quad (3)$$

$$\nabla \cdot \underline{B} = 0. \quad (4)$$

source free so $\underline{J} \rightarrow 0$, $\tilde{\rho} \rightarrow 0$

Take curl of (1)

$$\begin{aligned} \nabla \times \nabla \times \underline{E} &= - \frac{\partial}{\partial t} (\nabla \times \underline{B}) = - \mu \frac{\partial}{\partial t} (\nabla \times \underline{H}) \\ &= - \mu \frac{\partial}{\partial t} \left(\frac{\partial \underline{D}}{\partial t} \right) = - \mu \frac{\partial^2 \underline{D}}{\partial t^2} \end{aligned}$$

This is what we want on the right hand side.

Use a vector identity on the left-hand side

$$\nabla \times \nabla \times \underline{E} = \nabla (\nabla \cdot \underline{E}) - \nabla^2 \underline{E}$$

where we note $\nabla \cdot \underline{E} \rightarrow 0$ since $\tilde{\rho} \rightarrow 0$.

This gives us the simple wave equation for \underline{E}

$$\nabla^2 \underline{E} - \mu \frac{\partial^2 \underline{E}}{\partial t^2} = 0$$

$$\nabla^2 \underline{H} - \mu \epsilon \frac{\partial^2 \underline{H}}{\partial t^2} = 0,$$

We can also start with (3) and get a similar result

$$\nabla \times \underline{H} = \overset{0}{\cancel{\underline{J}}} + \frac{\partial \underline{D}}{\partial t}$$

$$\nabla \times \nabla \times \underline{H} = \frac{\partial}{\partial t} (\nabla \times \underline{D})$$

$$\underbrace{\nabla (\nabla \cdot \underline{H}) - \nabla^2 \underline{H}}_{\text{goes to zero}} = \epsilon \frac{\partial}{\partial t} (\nabla \times \underline{E}) = \epsilon \frac{\partial}{\partial t} \left(-\frac{\partial \underline{B}}{\partial t} \right) = -\mu \epsilon \frac{\partial^2 \underline{H}}{\partial t^2}$$

goes to zero
since $\nabla \cdot \underline{B} \rightarrow 0$

$$\nabla^2 \underline{H} - \mu \epsilon \frac{\partial^2 \underline{H}}{\partial t^2} = 0$$

These equations can be treated as 3 scalar equations in a single dimension, i.e.,

$$\left(\frac{\partial^2}{\partial x^2} + \frac{\partial^2}{\partial y^2} + \frac{\partial^2}{\partial z^2} \right) E_x - \mu \epsilon \frac{\partial^2 E_x}{\partial t^2} = 0$$

These equations have general solutions of the form

$$E_x(z,t) = p_1(z - v_p t) + p_2(z + v_p t) \quad (5)$$

where $v_p = \frac{1}{\sqrt{\mu \epsilon}}$ and p_1, p_2 are arbitrary shape functions

For example.

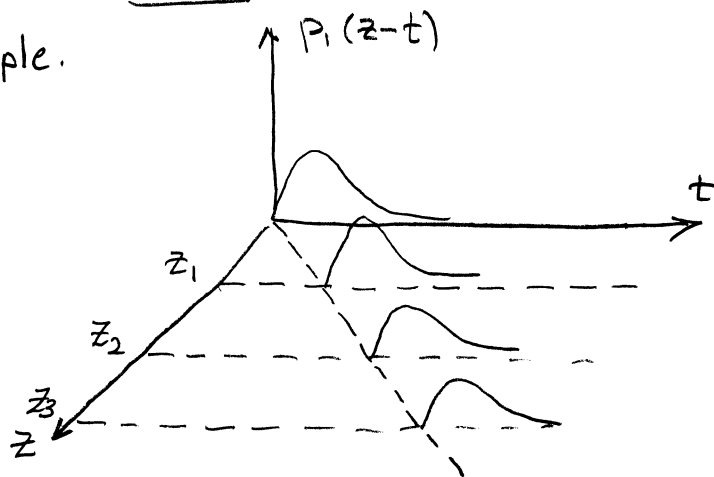

Each point in space sees a delayed (propagating) waveform.

Solutions of the form of (5) are known as plane waves since there are plane surfaces over which the argument of the function is constant, i.e.

$$z - v_p t = \text{constant.}$$

A plane of $z - t = 0$ is shown on the previous page.

We get exactly the same solutions for $\underline{\xi}_y$.

However, $\underline{\xi}_z$ does NOT exist.

$$\text{Consider, } \nabla \cdot \underline{\xi} = 0 \rightarrow \nabla \cdot \underline{\xi} = \frac{\partial \xi_x}{\partial x} + \frac{\partial \xi_y}{\partial y} + \frac{\partial \xi_z}{\partial z} = 0.$$

$$\frac{\partial \xi_x}{\partial x} = 0 \text{ since no dependence on } x.$$

$$\frac{\partial \xi_y}{\partial y} = 0 \text{ for the same reason. This forces } \frac{\partial \xi_z}{\partial z} = 0.$$

Impedance of the media relates $\underline{\xi}$ and \underline{H}

Consider $\underline{\xi}_x(z, t) = P_1(z - v_p t)$ where $\xi_y, \xi_z = 0$

$$\nabla \times \underline{\xi} = -\frac{\partial \mathcal{B}}{\partial t}$$

$$\begin{vmatrix} \hat{x} & \hat{y} & \hat{z} \\ \frac{\partial}{\partial x} & \frac{\partial}{\partial y} & \frac{\partial}{\partial z} \\ \xi_x & 0 & 0 \end{vmatrix} = \hat{y} \frac{\partial \xi_x}{\partial z} - \hat{z} \frac{\partial \xi_x}{\partial y}$$

$$-\frac{\partial \mathcal{B}}{\partial t} = -\mu \left(\hat{y} \frac{\partial H_x}{\partial z} + \hat{z} \frac{\partial H_x}{\partial y} \right)$$

$$\therefore \hat{y} \frac{\partial \xi_x}{\partial z} = -\mu \hat{x} \frac{\partial H_x}{\partial t} - \mu \hat{y} \frac{\partial H_y}{\partial t}$$

Let's look at the \underline{H} components for this solution.

[Inan & Inan, p.25; Collin & Plonsey, p. 308].

$$\nabla \times \underline{E} = -\mu \frac{\partial \underline{H}}{\partial t}$$

$$-\mu \frac{\partial \underline{H}}{\partial t} = \begin{vmatrix} \hat{x} & \hat{y} & \hat{z} \\ \frac{\partial}{\partial x} & \frac{\partial}{\partial y} & \frac{\partial}{\partial z} \\ E_x & 0 & 0 \end{vmatrix} = \hat{y} \frac{\partial E_x}{\partial z}$$

$$\therefore \frac{\partial H_y}{\partial t} = -\frac{1}{\mu} \frac{\partial E_x}{\partial z} = -\frac{1}{\mu} \frac{\partial P_1}{\partial (z-v_p t)} \frac{\partial (z-v_p t)}{\partial z}$$

integrating wrt time

$$H_y = -\frac{1}{\mu} \int \frac{\partial P_1}{\partial (z-v_p t)} dt = -\frac{1}{\mu} \int \frac{\partial P_1}{\partial (z-v_p t)} \left(-\frac{1}{v_p} \right) \partial (z-v_p t)$$

$$= + \frac{1}{\mu v_p} P_1(z-v_p t)$$

$$\text{since } v_p = \frac{1}{\sqrt{\mu \epsilon}} \quad \frac{1}{\mu v_p} = \frac{1}{\mu \frac{1}{\sqrt{\mu \epsilon}}} = \frac{1}{\sqrt{\frac{\mu}{\epsilon}}} = \frac{1}{\eta}$$

$$\therefore H_y = \frac{1}{\eta} P_1(z-v_p t)$$

this is the intrinsic impedance of the medium
has units of ohms

$$\text{free space } \eta = \sqrt{\frac{\mu_0}{\epsilon_0}} \cong 120\pi = 377\Omega$$

Figures p. 26

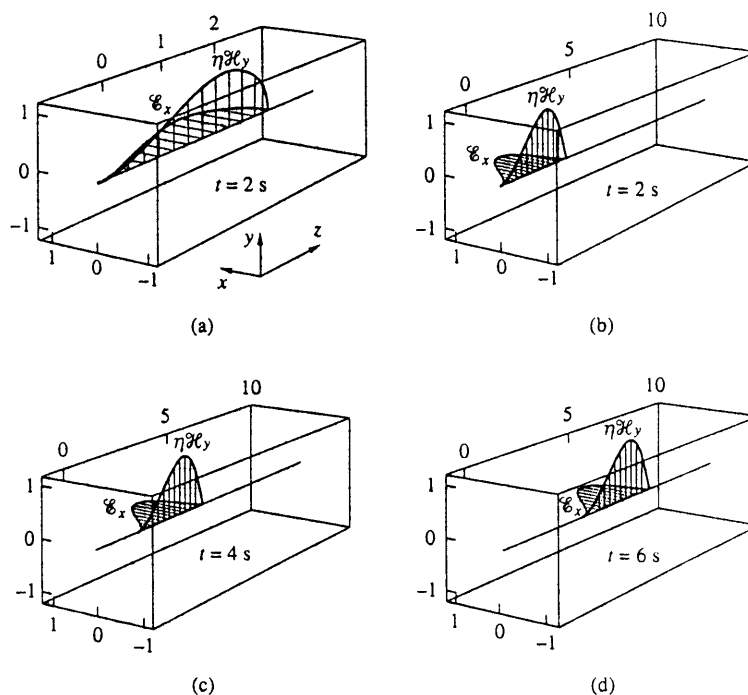

FIGURE 2.2. The propagation of a uniform plane electromagnetic disturbance in the z direction. The electric and magnetic fields are orthogonal at all times. For the purpose of this figure, the speed of propagation is taken to be $v_p = 1 \text{ m}\cdot\text{s}^{-1}$. (a) $\mathcal{E}_x(z, t)$ and $\eta\mathcal{H}_y(z, t)$ as a function of z at $t = 2$ s. (b) Same as (a) but shown on a compressed distance scale. (c) $\mathcal{E}_x(z, t)$ and $\eta\mathcal{H}_y(z, t)$ as a function of z at $t = 4$ s. (d) $\mathcal{E}_x(z, t)$ and $\eta\mathcal{H}_y(z, t)$ as a function of z at $t = 6$ s. The propagation of the pulse in the $+z$ direction is clearly evident. Note that the pulse shapes for the electric and magnetic fields are identical.

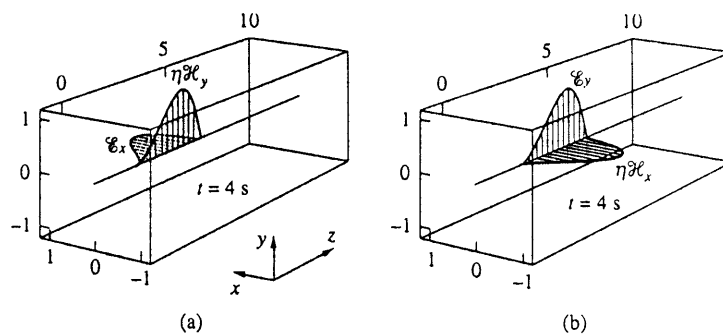

FIGURE 2.3. Electric and magnetic fields of a uniform plane wave. The relationship between $\vec{\mathcal{E}}$ and $\vec{\mathcal{H}}$ for a uniform plane wave is independent of the choice of a particular coordinate system. (a) $\mathcal{E}_x(z, t)$ and $\eta\mathcal{H}_y(z, t)$. (b) $\mathcal{E}_y(z, t)$ and $\eta\mathcal{H}_x(z, t)$.

2.2. Time harmonic electromagnetic waves

These are some of the most useful applications.

Valid because

- (a) signals are narrow band
- (b) signals can be represented as sum of Fourier components.

$$\text{let } \underline{\underline{E}}(x, y, z, t) = \text{Re} \{ \underline{E} e^{j\omega t} \}$$

Essentially as before

$$\nabla \times \underline{E} = -\frac{\partial \underline{B}}{\partial t} = -\mu \frac{\partial \underline{H}}{\partial t}$$

$$\underline{\nabla} \times \underline{\nabla} \times \underline{E} = -\mu \frac{\partial}{\partial t} (\underline{\nabla} \times \underline{H}) = -\mu \frac{\partial}{\partial t} \left(\frac{\partial \underline{D}}{\partial t} \right)$$

$$\nabla \cdot (\nabla \cdot \underline{E}) - \nabla^2 \underline{E} = -\mu \epsilon \frac{\partial^2 \underline{E}}{\partial t^2}$$

up till now there has been no difference

but since we are assuming $\underline{E} e^{j\omega t}$

$$\frac{\partial^2 \underline{E}}{\partial t^2} = (j\omega)^2 \underline{E} = -\omega^2 \underline{E}$$

$$-\nabla^2 \underline{E} = -\mu \epsilon (-\omega^2 \underline{E}) = +\omega^2 \mu \epsilon \underline{E}$$

$$\nabla^2 \underline{E} + \omega^2 \mu \epsilon \underline{E} = 0$$

$$\nabla^2 \underline{E} + \beta^2 \underline{E} = 0 \quad \text{where } \beta = \omega \sqrt{\mu \epsilon}$$

This is the Helmholtz equation, or vector wave equation

β is called the propagation constant

Let's begin by looking at solutions of the form

$$\underline{E}(x, y, z) = \hat{x} E_x(z)$$

When this is substituted into the Helmholtz equation we get

$$\left[\frac{\partial^2}{\partial x^2} + \frac{\partial^2}{\partial y^2} + \frac{\partial^2}{\partial z^2} \right] \hat{x} E_x(z) + \beta^2 \hat{x} E_x(z) = 0$$

go to zero since
 E_x not a function of x, y

After dropping the unit vector

$$\frac{d^2 E_x(z)}{dz^2} + \beta^2 E_x(z) = 0$$

The solutions of this equation are well known

$$E_x(z) = \underbrace{c_1 e^{-j\beta z}}_{E_x^+} + \underbrace{c_2 e^{+j\beta z}}_{E_x^-}$$

Look at real fields

$$E_x(z, t) = \text{Re} \left\{ c_1 e^{-j\beta z} e^{j\omega t} + c_2 e^{+j\beta z} e^{j\omega t} \right\}$$

$$= c_1 \cos(\omega t - \beta z) + c_2 \cos(\omega t + \beta z)$$

wave traveling in
 $+z$ direction

wave traveling in
 $-z$ direction.

You can verify this by following a point
 with constant phase, i.e. $\omega t - \beta z = \text{const}$

This travels at velocity $\omega t - \beta z = 0$

$$\frac{dz}{dt} = \frac{\omega}{\beta} \equiv v_p.$$

v_p is NOT this simple for lossy media or guiding structures.

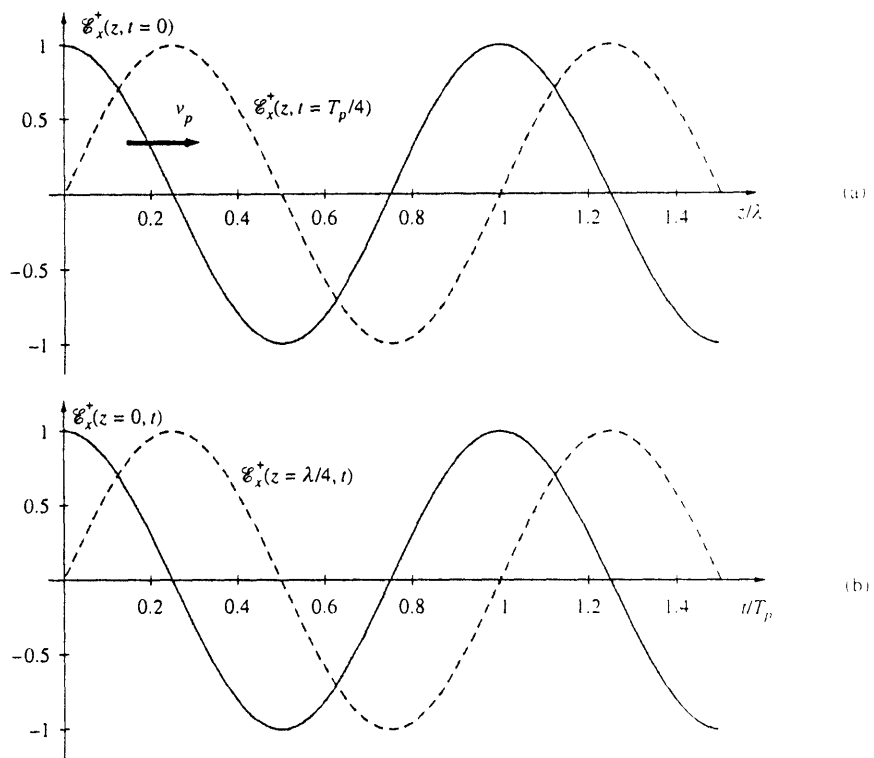

FIGURE 2.4. Wave behavior in space and time. (a) $E_x^+(z, t) = \cos[(2\pi/T_p)t - (2\pi/\lambda)z]$ versus z/λ and for $t = 0$ and $t = T_p/4$. (b) $E_x^+(z, t)$ versus t/T_p for $z = 0$ and $z = \lambda/4$

Notice how these waves are propagating,
 The upper one shows

$$E_x^+(z, t=0)$$

Notice that at $t = \frac{T_p}{4}$ it has shifted to the right by

$$\frac{\pi}{4} \quad T_p = \frac{1}{\nu_p}$$

The wave is
$$E_x^+(z, t) = \cos\left[\frac{2\pi}{T_p}t - \frac{2\pi}{\lambda}z\right].$$

The lower waveform shows the waveform at two different points in space as a function of time.

Once you know the electric field you can derive the magnetic field from it:

$$\underline{\nabla} \times \underline{E} = \begin{vmatrix} \hat{x} & \hat{y} & \hat{z} \\ \frac{\partial}{\partial x} & \frac{\partial}{\partial y} & \frac{\partial}{\partial z} \\ E_x & 0 & 0 \end{vmatrix} = \hat{y} \frac{\partial E_x(z)}{\partial z} = -j\omega\mu \underline{H} = -j\omega\mu [\hat{x}H_x + \hat{y}H_y + \hat{z}H_z]$$

for this example

so, \underline{H} has only a \hat{y} component given by

$$\begin{aligned} H_y(z) &= \frac{1}{-j\omega\mu} \frac{\partial E_x}{\partial z} = \frac{1}{-j\omega\mu} \frac{d}{dz} [c_1 e^{-j\beta z} + c_2 e^{+j\beta z}] \\ &= \frac{1}{-j\omega\mu} [-j\beta c_1 e^{-j\beta z} + j\beta c_2 e^{+j\beta z}] \\ &= \frac{-j\beta}{-j\omega\mu} [c_1 e^{-j\beta z} - c_2 e^{+j\beta z}] \\ &= \frac{1}{\eta} [c_1 e^{-j\beta z} - c_2 e^{+j\beta z}] \end{aligned}$$

This is very significant. Consider only the wave propagating in +z

$$E_x(z,t) = c_1 \cos(\omega t - \beta z)$$

We have just showed that this corresponds to

$$H_y(z,t) = \frac{c_1}{\eta} \cos(\omega t - \beta z)$$

Note that $\hat{x} \times \hat{y} = \hat{z}$, the direction of propagation

This is known as a TEM, transverse electromagnetic wave

Basically, only λ changes as the material changes.

Example 2-2 FM Broadcast signal

$$\underline{H}(y) = 2.92 \times 10^{-3} e^{-j0.68\pi y} (-\hat{x} + j\hat{z}) \frac{A}{m}$$

(a) This wave is propagating in the y-direction with form $e^{-j\beta y}$

By inspection $\beta = \omega \sqrt{\mu\epsilon} = 0.68\pi \frac{\text{rad}}{m}$

and we know that $f = \frac{\omega}{2\pi}$ and $v_p = \frac{1}{\sqrt{\mu\epsilon}} = c = 3 \times 10^8 \frac{m}{s}$

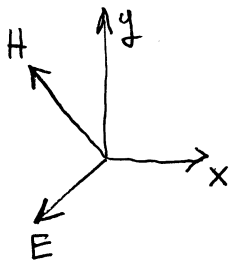

Quickly. $f = \frac{\beta/\sqrt{\mu\epsilon}}{2\pi} = \frac{\beta}{2\pi\sqrt{\mu\epsilon}} = \frac{0.68\pi}{2\pi} \times 3 \times 10^8 \frac{m}{s}$

$f = 102 \text{ MHz}$

Since $\beta = \frac{2\pi}{\lambda}$ $\lambda = \frac{2\pi}{\beta} = \frac{2\pi}{0.68\pi} m = 2.94 m$

(b) Since this is a "complex" wave with multiple components $\nabla \times \underline{H} = \frac{\partial \underline{D}}{\partial t}$

$$\frac{\partial \epsilon \underline{E}}{\partial t} = \nabla \times \underline{H}$$

$$\nabla \times \underline{H} = \begin{bmatrix} \hat{x} & \hat{y} & \hat{z} \\ \frac{\partial}{\partial x} & \frac{\partial}{\partial y} & \frac{\partial}{\partial z} \\ H_x & 0 & H_z \end{bmatrix}$$

$\therefore \epsilon j\omega_0 \underline{E} = \hat{x} \frac{\partial H_z}{\partial y} - \hat{z} \frac{\partial H_x}{\partial y}$

where we note that only $\frac{\partial}{\partial y} \neq 0$

$$\underline{E} = \frac{1}{j\omega\epsilon_0} \left[\hat{x} 2.92 \times 10^{-3} (-j0.68\pi) e^{-j0.68\pi y} - \hat{z} (-2.92 \times 10^{-3}) (-j0.68\pi) e^{-j0.68\pi y} \right]$$

$$= \frac{(2.92 \times 10^{-3})(0.68\pi)}{\omega\epsilon_0} [-j\hat{x} - \hat{z}] e^{-j0.68\pi y}$$

$$= \frac{(2.92 \times 10^{-3})(0.68\pi)}{(2\pi)(102 \times 10^6)(8.854 \times 10^{-12})} [-j\hat{x} - \hat{z}] e^{-j0.68\pi y}$$

$\underline{E}(y) \cong 1.099 [-j\hat{x} - \hat{z}] e^{-j0.68\pi y}$

2.3 Plane Waves in Lossy Media

The big change is that $\sigma \neq 0$, i.e. a \underline{J} term is present

$$\text{i.e. } \underline{\nabla} \times \underline{H} = \underline{J} + \frac{\partial \underline{D}}{\partial t}, \quad \underline{\nabla} \times \underline{E} = -\frac{\partial \underline{B}}{\partial t}$$

For time harmonic waves where we assume $\underline{E} = \text{Re}[\underline{E} e^{j\omega t}]$

$$\text{this becomes } \underline{\nabla} \times \underline{H} = \sigma \underline{E} + j\omega \epsilon \underline{E} = (\sigma + j\omega \epsilon) \underline{E}$$

Deriving the wave equation we start with:

$$\underline{\nabla} \times \underline{E} = -\frac{\partial \underline{B}}{\partial t} = -\mu \frac{\partial \underline{H}}{\partial t} = -j\omega \mu \underline{H}$$

Then take the curl

$$\begin{aligned} \underline{\nabla} \times \underline{\nabla} \times \underline{E} &= -j\omega \mu (\underline{\nabla} \times \underline{H}) \\ \underline{\nabla}(\underline{\nabla} \cdot \underline{E}) - \nabla^2 \underline{E} &= -j\omega \mu (\sigma + j\omega \epsilon) \underline{E} \end{aligned}$$

this is the new term

$$\therefore \nabla^2 \underline{E} - j\omega \mu (\sigma + j\omega \epsilon) \underline{E} = 0$$

looks like previous solutions if we define $\gamma^2 = j\omega \mu (\sigma + j\omega \epsilon)$ instead of β

$$\nabla^2 \underline{E} - \gamma^2 \underline{E} = 0$$

This has solutions if we assume $\gamma = \alpha + j\beta$

$$\begin{aligned} E_x(z) &= C_1 e^{-\gamma z} + C_2 e^{+\gamma z} \\ &= \underbrace{C_1 e^{-\alpha z} e^{-j\beta z}}_{E_x^+(z)} + \underbrace{C_2 e^{+\alpha z} e^{+j\beta z}}_{E_x^-(z)} \end{aligned}$$

$$\gamma^2 = -\omega^2 \mu \epsilon + j\omega \mu \sigma \quad \text{or} \quad \gamma = \alpha + j\beta$$

We can relate these by squaring $(\alpha + j\beta)$ and equating it to our physical definition from Maxwell's Equations

$$\gamma^2 = (\alpha + j\beta)^2 = -\omega^2 \mu \epsilon + j\omega \mu \sigma$$

↓ lots of algebra

sign

$$\alpha^2 - 2j\alpha\beta - \beta^2 = -\omega^2 \mu \epsilon + j\omega \mu \sigma$$

Equating real & imaginary parts

$$\alpha^2 - \beta^2 = -\omega^2 \mu \epsilon \quad (1) \quad -2j\alpha\beta = j\omega \mu \sigma$$

Squaring and adding both expressions ^{sign}

$$(\alpha^2 - \beta^2)^2 = \omega^4 \mu^2 \epsilon^2$$

$$-4\alpha^2 \beta^2 = -\omega^2 \mu^2 \sigma^2 \quad \text{used + signs}$$

$$(\alpha^2 - \beta^2)^2 + (2\alpha\beta)^2 = \omega^4 \mu^2 \epsilon^2 + \omega^2 \mu^2 \sigma^2$$

$$\alpha^4 - 2\alpha^2 \beta^2 + \beta^4 + 4\alpha^2 \beta^2 = \omega^4 \mu^2 \epsilon^2 + \omega^2 \mu^2 \sigma^2 \quad \text{after expanding terms}$$

These terms complete a square.

$$(\alpha^2 + \beta^2)^2 = \omega^4 \mu^2 \epsilon^2 \left[1 + \left(\frac{\sigma}{\omega \epsilon} \right)^2 \right]$$

factored out $\omega^4 \mu^2 \epsilon^2$
This $\left(\frac{\sigma}{\omega \epsilon} \right)$ term will appear over & over.

$$\text{or } (\alpha^2 + \beta^2) = \omega^2 \mu \epsilon \sqrt{1 + \left(\frac{\sigma}{\omega \epsilon} \right)^2} \quad (2)$$

Now we solve for α and β .

$$\text{Adding (1) + (2): } 2\alpha^2 = \omega^2 \mu \epsilon \sqrt{1 + \left(\frac{\sigma}{\omega \epsilon} \right)^2} - \omega^2 \mu \epsilon$$

$$\alpha = \omega \sqrt{\frac{\mu \epsilon}{2}} \left[\sqrt{1 + \left(\frac{\sigma}{\omega \epsilon} \right)^2} - 1 \right]^{\frac{1}{2}}$$

$$\text{Subtracting (2) - (1): } 2\beta^2 = \omega^2 \mu \epsilon \sqrt{1 + \left(\frac{\sigma}{\omega \epsilon} \right)^2} + \omega^2 \mu \epsilon$$

$$\beta = \omega \sqrt{\frac{\mu \epsilon}{2}} \left[\sqrt{1 + \left(\frac{\sigma}{\omega \epsilon} \right)^2} + 1 \right]^{\frac{1}{2}}$$

The impedance for a lossy (conductive) medium becomes complex.

We previously found the impedance for time harmonic fields by deriving the \underline{H} field from a given \underline{E} using $\nabla \times \underline{E}$

If we repeat that process the only equation that is different is

$$\nabla \times \underline{H} = \sigma \underline{E} + j\omega \epsilon \underline{E} = j\omega \epsilon_{\text{eff}} \underline{E}$$

Where we define $\epsilon_{\text{eff}} = \epsilon - j \frac{\sigma}{\omega}$ $\left\{ \begin{array}{l} \sigma + j\omega \epsilon = j\omega \epsilon_{\text{eff}} \\ \epsilon_{\text{eff}} = \frac{\sigma}{j\omega} + \epsilon = \epsilon - j \left(\frac{\sigma}{\omega} \right) \end{array} \right.$

so we can write $\nabla \times \underline{H} = j\omega \epsilon_{\text{eff}} \underline{E}$

so all the equations are as before giving the same result

However, η_c is now complex. Consider

conducting $\eta_c = \sqrt{\frac{\mu}{\epsilon_{\text{eff}}}} = \sqrt{\frac{\mu}{\epsilon - j \frac{\sigma}{\omega}}} = \sqrt{\frac{\mu}{\epsilon (1 - j \frac{\sigma}{\omega \epsilon})}}$

where we now use the effective ϵ

$$= \frac{\sqrt{\frac{\mu}{\epsilon}}}{(1 - j \frac{\sigma}{\omega \epsilon})^{\frac{1}{2}}} = \frac{\sqrt{\frac{\mu}{\epsilon}}}{\sqrt{\left[(1)^2 + \left(\frac{\sigma}{\omega \epsilon} \right)^2 \right]^{\frac{1}{2}} e^{j \frac{1}{2} \tan^{-1} \left(\frac{\sigma}{\omega \epsilon} \right)}}$$

do in polar so we can take square root.

$$= \frac{\sqrt{\frac{\mu}{\epsilon}}}{\left(1 + \left(\frac{\sigma}{\omega \epsilon} \right)^2 \right)^{\frac{1}{4}} e^{-j \frac{1}{2} \tan^{-1} \left(\frac{\sigma}{\omega \epsilon} \right)}} = |\eta_c| e^{j\phi_n}$$

from square root

which is a complex number. Let's look at some simple fields

If $E_x^+(z) = C_1 e^{-\alpha z} e^{-j\beta z}$

Then $\underline{H} = \hat{y} H_y^+(z) = \hat{y} \frac{1}{\eta_c} C_1 e^{-\alpha z} e^{-j\beta z}$

Expanding this term using the expression for η_c

$$\begin{aligned} \underline{H} &= \hat{y} \frac{1}{|\eta_c| e^{j\phi_n}} c_1 e^{-\alpha z} e^{-j\beta z} \\ &= \hat{y} \frac{1}{|\eta_c|} c_1 e^{-\alpha z} e^{-j\beta z} e^{-j\phi_n} \end{aligned}$$

If we write these as time functions we get

$$\begin{aligned} \Sigma_x^+(z,t) &= \text{Re} \{ E_x^+(z) e^{j\omega t} \} = \text{Re} \{ c_1 e^{-\alpha z} e^{-j\beta z} e^{j\omega t} \} \\ &= c_1 e^{-\alpha z} \cos(\omega t - \beta z) \quad \text{No change in } \Sigma_x^+ \end{aligned}$$

$$\begin{aligned} H_y^+(z,t) &= \text{Re} \left\{ \frac{1}{|\eta_c|} c_1 e^{-\alpha z} e^{-j\beta z} e^{-j\phi_n} e^{j\omega t} \right\} \\ &= \frac{c_1}{|\eta_c|} e^{-\alpha z} \cos(\omega t - \beta z - \phi_n) \quad \text{Phase shift in } H_y^+ \end{aligned}$$

The E & H fields in a lossy media (for a plane wave) are out of phase!

α, β, η_c all depend on $\frac{\sigma}{\omega\epsilon}$

$\tan \delta_c = \frac{\sigma}{\omega\epsilon}$ is called the loss tangent.

2.3.1. Uniform Plane Wave Propagation in Lossy Dielectrics

in good insulating dielectrics

conduction current dominates at low frequencies

polarization currents dominate at high frequencies

This is very complicated. At high frequencies we use a complex dielectric constant

$$\epsilon_c = \epsilon' - j\epsilon''$$

includes frictional damping due to "inertia" of polarized particles and can include ohmic losses

$\sigma \underline{E} + j\omega \epsilon \underline{E} = \sigma \underline{E} + j\omega(\epsilon' - j\epsilon'') \underline{E} = \sigma \underline{E} + \omega \epsilon'' \underline{E} + j\omega \epsilon' \underline{E}$
This is slightly different than previous discussion of lossy media, where we assumed ohmic losses.

$$\underline{J} = \sigma \underline{E} = 0.$$

Instead of $\tan \delta_c = \frac{\sigma_{eff}}{\omega \epsilon}$ (loss tangent)

we have $\tan \delta_c = \frac{\omega \epsilon''}{\omega \epsilon'} = \frac{\epsilon''}{\epsilon'}$ } usually measured.

for complex media.

so we don't usually differentiate between

conduction and high-frequency polarization losses.

You can also model a complex permeability

$$\mu_c = \mu' - j\mu''$$

to get $\sigma_{eff} = \frac{\epsilon' \omega \mu''}{\mu'}$

which is the basis for MRI.

2.3.2 Uniform Plane Wave Propagation in a Good conductor

In this case $\frac{\sigma}{\omega\epsilon} \gg 1$.

If $\frac{\sigma}{\omega\epsilon} \gg 1$ then we can approximate γ

From page 11, $\gamma^2 = j\omega\mu(\sigma + j\omega\epsilon)$
 $= (j\omega\mu\sigma) \left[1 + j\frac{\omega\epsilon}{\sigma} \right]$

since $j = e^{j90^\circ}$
 $\frac{1}{\sqrt{2}} = e^{j45^\circ}$

Then $\gamma = \sqrt{j\omega\mu\sigma} = \sqrt{\omega\mu\sigma} e^{j45^\circ} = \sqrt{\omega\mu\sigma} \left(\frac{1}{\sqrt{2}} + \frac{j}{\sqrt{2}} \right)$

but as $\gamma = \alpha + j\beta$

$$\alpha = \beta \approx \sqrt{\frac{\omega\mu\sigma}{2}}$$

Plane waves in conductors (σ large)

(a) are heavily attenuated since $\alpha \sim \sigma^{1/2}$

(b) have a significant phase shift per unit length

since $\beta \sim \sigma^{1/2}$

The impedance for conductors is given by [page 13]

$$\eta_c = \frac{\sqrt{\frac{\mu}{\epsilon}}}{(1 - j\frac{\sigma}{\omega\epsilon})^{1/2}} \approx \frac{\sqrt{\frac{\mu}{\epsilon}}}{\sqrt{-j\frac{\sigma}{\omega\epsilon}}} = \sqrt{\frac{j\omega\mu}{\sigma}} = \sqrt{\frac{\mu\omega}{\sigma}} e^{j45^\circ}$$

where we assumed $\frac{\sigma}{\omega\epsilon} \gg 1$

Note that η_c is (a) quite small so magnetic field LARGE

(b) $\phi_n \sim 45^\circ$ for all good conductors

so conductor looks like an inductor.

Useful parameter in characterizing good conductors is the skin depth.

$$\delta = \frac{1}{\alpha} \approx \sqrt{\frac{2}{\omega \mu \sigma}}$$

This is the $\frac{1}{e}$ depth a field penetrates a good conductor.

2.4 EM Energy Flow & the Poynting Vector.

We can represent power flow as the volume density of power dissipation represented by $\underline{j} \cdot \underline{E}$

Start with Maxwell's Eqn's.

$$\underline{E} = \nabla \times \underline{A} - \frac{\partial \Phi}{\partial t}$$

$$\underline{j} \cdot \underline{E} = \underline{j} \cdot (\nabla \times \underline{A}) - \underline{j} \cdot \frac{\partial \Phi}{\partial t}$$

this can be rewritten using the vector identity

$$\nabla \cdot (\underline{A} \times \underline{B}) \equiv \underline{B} \cdot (\nabla \times \underline{A}) - \underline{A} \cdot (\nabla \times \underline{B})$$

$$\underline{j} \cdot \underline{E} = -\nabla \cdot (\underline{j} \times \underline{A}) + \underline{A} \cdot (\nabla \times \underline{j}) - \underline{j} \cdot \frac{\partial \Phi}{\partial t}$$

$$\text{but } \nabla \times \underline{j} = -\frac{\partial \rho}{\partial t}$$

$$\underline{j} \cdot \underline{E} = -\nabla \cdot (\underline{j} \times \underline{A}) - \underline{A} \cdot \frac{\partial \rho}{\partial t} - \underline{j} \cdot \frac{\partial \Phi}{\partial t}$$

The two time derivatives can be re-written as

$$\underline{A} \cdot \frac{\partial \rho}{\partial t} = \underline{A} \cdot \frac{\partial (\nabla \cdot \underline{E})}{\partial t} = \frac{1}{2} \frac{\partial (\rho \underline{A} \cdot \underline{A})}{\partial t} = \frac{\partial}{\partial t} \left(\frac{1}{2} \rho |\underline{A}|^2 \right)$$

$$\underline{j} \cdot \frac{\partial \Phi}{\partial t} = \underline{j} \cdot \frac{\partial (\nabla \cdot \underline{A})}{\partial t} = \frac{1}{2} \frac{\partial (\underline{j} \cdot \underline{j})}{\partial t} = \frac{\partial}{\partial t} \left(\frac{1}{2} \epsilon |\underline{j}|^2 \right)$$

$$\underline{j} \cdot \underline{E} = -\frac{\partial}{\partial t} \left(\frac{1}{2} \rho |\underline{A}|^2 \right) - \frac{\partial}{\partial t} \left(\frac{1}{2} \epsilon |\underline{j}|^2 \right) - \nabla \cdot (\underline{j} \times \underline{A})$$

* See Section 5.8 Joule's Law, Inan & Inan, Engineering Electromagnetics
 $w = Q \Delta \Phi$ so $P = \frac{dw}{dt} = I \Delta \Phi$ where $d\Phi = \underline{E} \cdot d\underline{l} = \frac{\underline{E} \cdot \underline{J}}{J} dr$

Integrate over a volume V

$$\int_V \underline{\mathbf{E}} \cdot \underline{\mathbf{J}} \, dV = - \underbrace{\int_V \frac{\partial}{\partial t} \left(\frac{1}{2} \epsilon |\underline{\mathbf{E}}|^2 + \frac{1}{2} \mu |\underline{\mathbf{H}}|^2 \right) dV}_{\text{reverse order}} - \underbrace{\int_V \nabla \cdot (\underline{\mathbf{E}} \times \underline{\mathbf{H}}) dV}_{\text{use Divergence Theorem}}$$

$$\underbrace{\int_V \underline{\mathbf{E}} \cdot \underline{\mathbf{J}} \, dV}_{\text{instantaneous power dissipated in the volume } V} = - \frac{\partial}{\partial t} \underbrace{\int_V \left[\frac{1}{2} \epsilon |\underline{\mathbf{E}}|^2 + \frac{1}{2} \mu |\underline{\mathbf{H}}|^2 \right] dV}_{\text{this is the rate at which the EM energy stored in the volume is decreasing (note negative sign)}} - \underbrace{\oint_S \underline{\mathbf{E}} \times \underline{\mathbf{H}} \cdot d\underline{\mathbf{S}}}_{\text{flow of energy (into) through the surface } S' \text{ enclosing } V}$$

instantaneous power dissipated in the volume V

this is the rate at which the EM energy stored in the volume is decreasing (note negative sign)

flow of energy (into) through the surface S' enclosing V

Poynting's Theorem

Poynting Vector $\underline{\mathbf{P}} = \underline{\mathbf{E}} \times \underline{\mathbf{H}}$

Example 2-13 Power Flow in a coaxial line

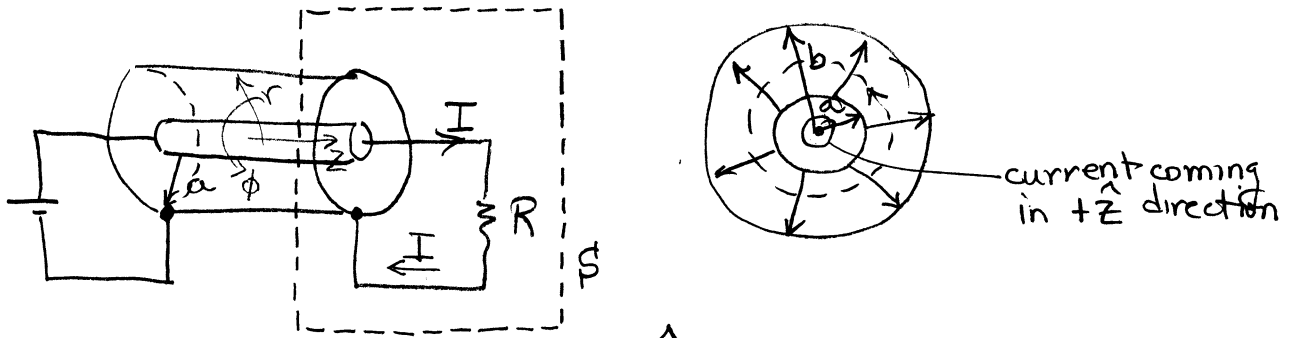

Using Ampere's Law $\oint \underline{H} = \frac{I}{2\pi r} \hat{\phi} \quad a < r < b$

The electric field can be found using Laplace's Equation

$$\nabla^2 \Phi = \frac{1}{r} \frac{\partial}{\partial r} \left(r \frac{\partial \Phi}{\partial r} \right) + \frac{1}{r^2} \frac{\partial^2 \Phi}{\partial \phi^2} + \frac{\partial^2 \Phi}{\partial z^2} = 0$$

because of symmetry

$$\frac{1}{r} \frac{\partial}{\partial r} \left(r \frac{\partial \Phi}{\partial r} \right) = 0$$

integrating $\Phi(r) = c_1 \ln r + c_2$

$$\Phi(r=a) = +V$$

$$V = c_1 \ln(a) + c_2$$

$$\Phi(r=b) = 0.$$

$$0 = c_1 \ln(b) + c_2$$

$$V = c_1 [\ln(a) - \ln(b)]$$

$$c_1 = \frac{V}{\ln(a) - \ln(b)} = \frac{V}{\ln\left(\frac{a}{b}\right)}$$

$$c_2 = -c_1 \ln b = -\frac{V}{\ln\left(\frac{a}{b}\right)} \ln(b)$$

$$\therefore \Phi(r) = \frac{V \ln(r)}{\ln\left(\frac{a}{b}\right)} - \frac{V \ln(b)}{\ln\left(\frac{a}{b}\right)} = V \frac{\ln\left(\frac{r}{b}\right)}{\ln\left(\frac{a}{b}\right)}$$

$$|\mathbf{m}| = -\nabla\Phi = -\left[\hat{r}\frac{\partial\Phi}{\partial r} + \hat{\phi}\frac{1}{r}\frac{\partial\Phi}{\partial\phi} + \hat{z}\frac{\partial\Phi}{\partial z}\right]$$

$$|\mathbf{m}| = -\hat{r}\frac{\partial\Phi}{\partial r} = -\hat{r}\frac{1}{\ln(b/a)} = -\hat{r}\frac{V}{r\ln(b/a)}$$

$$|\mathbf{m}| = \hat{r}\frac{V}{r\ln(b/a)}$$

Compute the power flow

$$\oint_S (\underline{\mathbf{E}} \times \underline{\mathbf{H}}) \cdot d\underline{\mathbf{S}} = \int_a^b \int_0^{2\pi} \frac{V}{r\ln(b/a)} \frac{I}{2\pi r} \hat{z} \cdot \underbrace{\hat{z} r dr d\phi}_{\text{differential surface element}}$$

$$= \frac{VI}{\ln(b/a)} \int_a^b \frac{2\pi r}{r(2\pi r)} dr$$

$$= \frac{VI}{\ln(b/a)} \int_a^b \frac{dr}{r} = \frac{VI}{\ln(b/a)} [\ln(b) - \ln(a)]$$

$$= \frac{VI}{\ln(b/a)} \ln(b/a) = \underline{\underline{VI}}$$

Example 2-14 Energy flow in a capacitor

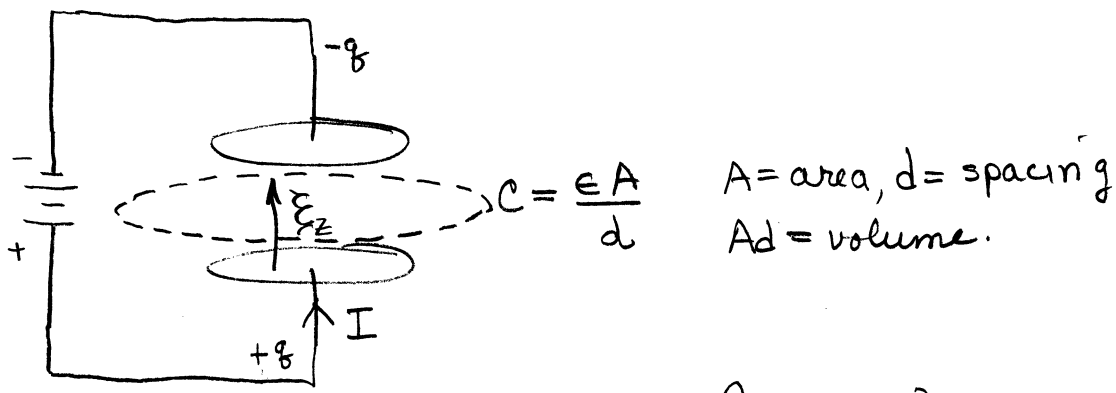

Assuming uniform E field $W_e = \int_V \frac{1}{2} \epsilon (\underline{E}_z)^2 dV = \frac{1}{2} \epsilon \underline{E}_z^2 Ad$

$$\frac{dW_e}{dt} = Ad \frac{d}{dt} \left(\frac{1}{2} \epsilon \underline{E}_z^2 \right) = \epsilon Ad \underline{E}_z \frac{d\underline{E}_z}{dt}$$

Since $\frac{dW_e}{dt}$ there is a flow of energy into the region between the plates. Since \underline{E} is \perp to plates and an \underline{H} would be in $\hat{\phi}$ direction, $\underline{E} \times \underline{H}$ would be parallel to the plates so energy is NOT arriving through wires.

Let's compute \underline{H} from the electric field. (Ampere's Law)

choose a circular contour whose plane goes through Ad, radius = r

$$\oint_C \underline{H} \cdot d\underline{l} = \int_S \frac{\partial(\epsilon \underline{E})}{\partial t} \cdot d\underline{s}$$

no current in volume between plates.

$$\underline{H}_\phi (2\pi r) = \epsilon (\pi r^2) \frac{\partial \underline{E}_z}{\partial t}$$

surface area

$$\underline{H}_\phi = \frac{\epsilon r}{2} \frac{\partial \underline{E}_z}{\partial t}$$

No physical γ but there is a displacement current $\frac{\partial Q}{\partial t}$ in the region between plates $\frac{\partial Q}{\partial t}$

everywhere in volume between plates.

For these \underline{E} & \underline{H} fields

$$\underline{P} = \underline{E} \times \underline{H} = \underline{E}_z \hat{z} \times \hat{\phi} H_\phi = -\hat{r} \underline{E}_z H_\phi$$

energy is coming from sides of cylindrical volume between plates.

Total flow into region comes from integrating Φ over cylindrical side surface of capacitor

$$-\oint_S \underline{\Phi} \cdot d\underline{s} = \int_0^d \int_{\phi=0}^{2\pi} \sum_z \left(\frac{\epsilon a}{2} \frac{\partial \underline{E}_z}{\partial t} \right) a dz d\phi$$

assume $r=a$

$$= 2\pi d \frac{\epsilon a^2}{2} \left(\sum_z \frac{\partial \underline{E}_z}{\partial t} \right)$$

$$= \pi a^2 d \frac{\partial}{\partial t} \left(\frac{1}{2} \epsilon \underline{E}_z^2 \right) = Ad \frac{\partial}{\partial t} \left(\frac{1}{2} \epsilon \underline{E}_z^2 \right)$$

which agrees with original expression.

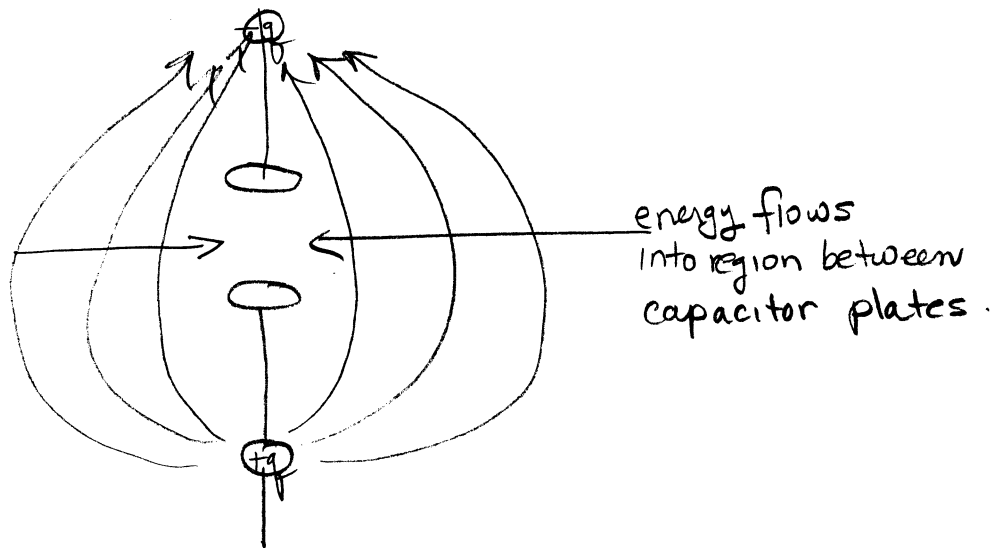

power supplied into region from sides is equal to

$$W_e = \int_V \frac{1}{2} \epsilon \underline{E}_z^2 dV = \frac{1}{2} \epsilon \underline{E}_z^2 A d.$$

2.4.2. EM Power Carried by a Uniform Plane Wave in a Lossless Medium

transverse
wave solution

$$\underline{E}_x = E_0 \cos(\omega t - \beta z)$$

$$\underline{H}_y = \frac{1}{\eta} E_0 \cos(\omega t - \beta z)$$

↑
script indicates total (time & space)

Poynting vector

$$\begin{aligned} \underline{P} &= \underline{E} \times \underline{H} = \hat{x} \times \hat{y} \frac{E_0^2}{\eta} \cos^2(\omega t - \beta z) \\ &= \hat{z} \frac{E_0^2}{2\eta} [1 + \cos(2(\omega t - \beta z))] \end{aligned}$$

I used a trig identity
 $\cos(\theta) = \frac{1}{2} [1 + \cos 2\theta]$

This allows us to consider the time dependent behavior of energy flow (power). Usually we are not interested in the instantaneous flow but the time averaged flow. When you time average the term at $2(\omega t - \beta z)$ disappears and only the DC term remains

$$\underline{S}_{AV} = \frac{1}{T_P} \int_0^{T_P} \underline{P}(z,t) dt = \frac{1}{T_P} \int_0^{T_P} \hat{z} \frac{E_0^2}{2\eta} [1 + \cancel{\cos 2(\omega t - \beta z)}] dt$$

T_P is the period of the wave

$$T_P = \frac{2\pi}{\omega}$$

$$\underline{S}_{AV} = \hat{z} \frac{E_0^2}{2\eta}$$

factor of 2 comes from time averaging

Remember that Poynting's Theorem has three terms:

$$\underbrace{\int_V \vec{E} \cdot \vec{J} \, dV}_{\text{this would be zero}} = -\frac{\partial}{\partial t} \int_V \left[\frac{1}{2} \epsilon |\vec{E}|^2 + \frac{1}{2} \mu |\vec{H}|^2 \right] dV - \underbrace{\oint_S (\vec{E} \times \vec{H}) \cdot d\vec{s}}_{\text{we just calculated this term as}}$$

this would be zero since the wave is propagating in a lossless media

we just calculated this term as

$$S_{AV} = \hat{z} \frac{E_0^2}{2\eta}$$

what does this term look like? Let's calculate W_e and W_m which is the energy stored in the electric & magnetic fields.

$$W_e = \frac{1}{2} \epsilon |\vec{E}_x|^2 = \frac{1}{2} \epsilon E_0^2 \cos^2(\omega t - \beta z)$$

$$W_m = \frac{1}{2} \mu |\vec{H}_y|^2 = \frac{1}{2} \mu \frac{E_0^2}{\eta^2} \cos^2(\omega t - \beta z)$$

$$\eta = \sqrt{\frac{\mu}{\epsilon}}$$

$$= \frac{1}{2} \cancel{\mu} \frac{E_0^2}{\cancel{\mu/\epsilon}} \cos^2(\omega t - \beta z) = \frac{1}{2} \epsilon E_0^2 \cos^2(\omega t - \beta z)$$

Important observation: instantaneously $W_e = W_m$
However, we are interested in time averaged quantities as before.

$$\begin{aligned} \overline{W_e} = \overline{W_m} &= \frac{1}{T_p} \int_0^{T_p} \frac{1}{2} \epsilon E_0^2 \cos^2(\omega t - \beta z) dt = \\ &= \frac{1}{2} \epsilon E_0^2 \frac{1}{T_p} \int_0^{T_p} \left[\frac{1}{2} + \frac{1}{2} \cos[2(\omega t - \beta z)] \right] dt \\ &= \frac{1}{4} \epsilon E_0^2 \end{aligned}$$

Example 2-17 FM broadcasting

(a) 92.3 MHz KGON 100kW

calculate time averaged power 50m away from antenna

With antennas you have to first consider near field versus far field. See p. 487 which defines

far field as $\beta r \gg 1$ or $(\frac{2\pi}{\lambda})r \gg 1$ or $r \gg \frac{\lambda}{2\pi} \approx 0.16\lambda$

\uparrow
r = distance from antenna

* This is also called Fraunhofer field. (comes from optics)
See p. 485 for near-field & far-field.

We have to compute λ .

$$\lambda = \frac{c}{f} = \frac{3 \times 10^8 \text{ m/sec}}{92.3 \times 10^6 / \text{sec}} \approx 3.25 \text{ m}$$

Since $50 \text{ m} \gg \lambda$ we are in far-field.

You want to be in far field because there are many issues in accurately describing near-field radiation patterns.

Once this is done the actual calculation is simple. Assume a isotropic radiator centered on the antenna.

$$|\underline{S}_{AV}| = \frac{P_{tot}}{4\pi R^2} \leftarrow \text{surface area of sphere} = \frac{100 \times 10^3}{4\pi (50)^2} \approx 3.18 \text{ W/m}^2 = 0.318 \frac{\text{mW}}{\text{cm}^2}$$

This exceeds IEEE Safety Levels of $0.2 \frac{\text{mW}}{\text{cm}^2}$

(b) safe distance for this standard

$$0.2 \frac{\text{mW}}{\text{cm}^2} = \frac{P_{tot}}{4\pi R^2} \quad \therefore R = \sqrt{\frac{P_{tot}}{4\pi (0.2 \frac{\text{mW}}{\text{cm}^2})}} = \sqrt{\frac{100 \times 10^3}{4\pi (2)}} \approx 63.1 \text{ m}$$

(c) Now calculate for antenna on top of 200 m tower and person standing 50 m away on ground.

The only change here is geometry.

$$|S_{AV}| = \frac{P_{tot}}{4\pi [(200)^2 + (50)^2]} \approx 0.187 \frac{W}{m^2}$$

Putting the antenna up in the air now makes the 50 m distance safe.

NOTE: Most problems of this type deal with power and distance.

2.4.3 Complex Poynting Theorem.

Consider the case of a time-harmonic plane wave in a lossy medium

$$\underline{E}(z,t) = c_1 e^{-\alpha z} \cos(\omega t - \beta z) \hat{x}$$

$$\underline{H}(z,t) = \frac{c_1}{|\eta_c|} e^{-\alpha z} \cos(\omega t - \beta z - \phi_n) \hat{y}$$

$$\underline{P}(z,t) = \underline{E}(z,t) \times \underline{H}(z,t) = \frac{c_1^2}{2|\eta_c|} e^{-2\alpha z} \left[\cos(\phi_n) + \cos(2\omega t - 2\beta z - \phi_n) \right] \hat{z}$$

we use sum & difference formulas to combine product this way

We are usually interested in the time averaged \underline{P}

$$\underline{S}_{AV}(z) = \frac{1}{T_P} \int_0^{T_P} \underline{P}(z,t) dt = \hat{z} \frac{c_1^2}{2|\eta_c|} e^{-2\alpha z} \cos(\phi_n) \quad \text{the time dep. term goes away.}$$

Cannot simply substitute $\frac{\partial}{\partial t}$ to get complex version of Poynting's theorem. because of the vector products.

$$\begin{aligned} \nabla \times \underline{E} &= -j\omega \underline{B} \\ \nabla \times \underline{H} &= \underline{J} + j\omega \underline{D} \end{aligned}$$

Unlike previous Poynting's theorem we start with the vector identity

$$\begin{aligned} \nabla \cdot (\underline{E} \times \underline{H}^*) &= \underline{H}^* \cdot (\nabla \times \underline{E}) - \underline{E} \cdot (\nabla \times \underline{H}^*) \\ &= \underline{H}^* \cdot (-j\omega \underline{B}) - \underline{E} \cdot (\underline{J}^* - j\omega \underline{D}^*) \end{aligned}$$

Now integrate over V

$$\int_V \nabla \cdot (\underline{E} \times \underline{H}^*) dV = \int_S (\underline{E} \times \underline{H}^*) \cdot d\underline{S} = \int_V \left[-\underline{E} \cdot \underline{J}^* - j\omega (\underline{H}^* \cdot \underline{B} - \underline{E} \cdot \underline{D}^*) \right] dV$$

There are several cases we can consider

lossy conductor $\underline{J} = \sigma \underline{E}$

$$\oint_S (\underline{E} \times \underline{H}^*) \cdot d\underline{S} = - \int_V \sigma \underline{E} \cdot \underline{E}^* dv - j\omega \int_V (\mu \underline{H} \cdot \underline{H}^* - \epsilon \underline{E} \cdot \underline{E}^*) dv$$

for lossy dielectrics $\underline{J} = \sigma_{\text{eff}} \underline{E} = \omega \epsilon'' \underline{E}$ an "effective" conduction current

This is best analyzed by looking at real and imag parts of the Poynting vector

and noting that

$$P_c = \frac{1}{2} \sigma \underline{E} \cdot \underline{E}^*$$

this is the time average power dissipation of the conduction current.

and recalling that

$$\overline{W}_e = \overline{W}_m = \frac{1}{4} \epsilon E_0^2 = \frac{1}{4} \mu H_0^2$$

$$\oint_S (\underline{E} \times \underline{H}^*) \cdot d\underline{S} = \text{Re} \left\{ \oint_S (\underline{E} \times \underline{H}^*) \cdot d\underline{S} \right\} + j \text{Im} \left\{ \oint_S (\underline{E} \times \underline{H}^*) \cdot d\underline{S} \right\}$$

$$- \int_V \sigma \underline{E} \cdot \underline{E}^* dv = - 2 \int_V P_c dv$$

$$- j\omega \int_V (\mu \underline{H} \cdot \underline{H}^* - \epsilon \underline{E} \cdot \underline{E}^*) dv = - j 4\omega \int_V (\overline{W}_m - \overline{W}_e) dv$$

$$\therefore \operatorname{Re} \left\{ \oint_S (\underline{E} \times \underline{H}^*) \cdot d\underline{S} \right\} = -2 \int_V P_e dv$$

$$\operatorname{Im} \left\{ \oint_S (\underline{E} \times \underline{H}^*) \cdot d\underline{S} \right\} = -4\omega \int_V (\bar{W}_m - \bar{W}_e) dv$$

represents reactive
power flowing back & forth
between electric and
magnetic fields to supply
instantaneous changes
in the net stored energy

$$S_{av} = \frac{1}{2} \operatorname{Re} \left\{ \underline{E} \times \underline{H}^* \right\}$$

complex
Poynting
vector

2.5 Polarization of EM Waves

Linear polarization:

$$E_x(z,t) = C_{1x} \cos(\omega t - \beta z + \xi)$$

$$E_y(z,t) = C_{1y} \cos(\omega t - \beta z + \xi)$$

transverse components in phase

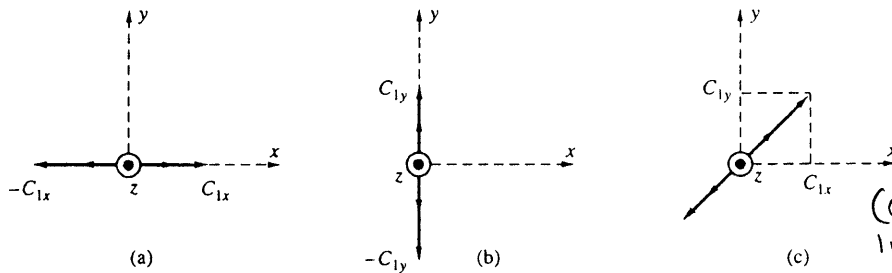

FIGURE 2.16. The electric field vector of a linearly polarized wave. (a) $C_{1x} \neq 0$ and $C_{1y} = 0$. (b) $C_{1x} = 0$ and $C_{1y} \neq 0$. (c) $C_{1x} \neq 0$ and $C_{1y} \neq 0$.

(c) is still linear because x & y are in phase.

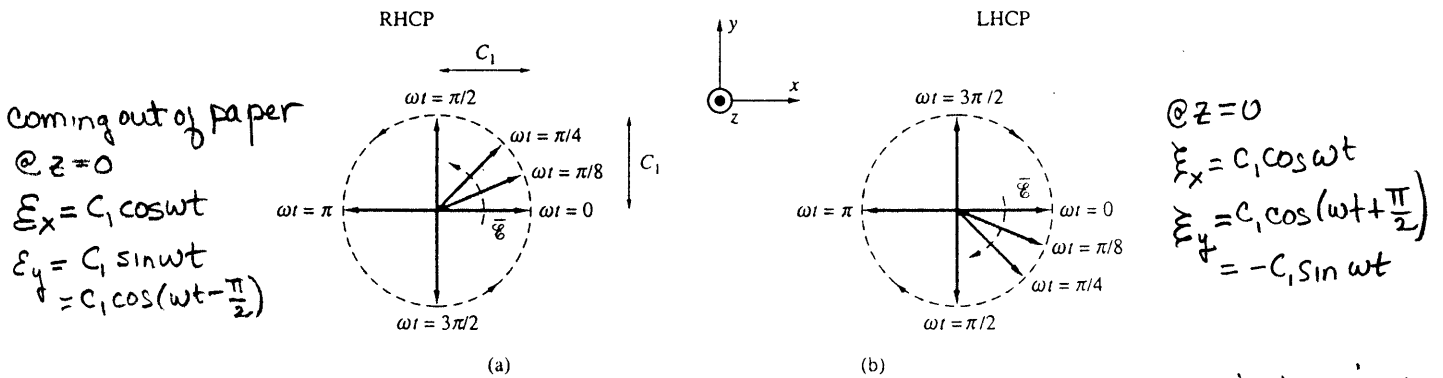

FIGURE 2.17. The electric field vectors of a right-hand and left-hand circularly polarized waves. (a) RHCP. (b) LHCP. In both cases, the positions of the total electric field vector are shown at different times as indicated. Note that the wave is assumed to be propagating in the $+z$ direction.

← spiraling determined by right hand rule

Coming out of paper
@ $z=0$
 $E_x = C_1 \cos \omega t$
 $E_y = C_1 \sin \omega t$
 $\psi = C_1 \cos(\omega t - \frac{\pi}{2})$

@ $z=0$
 $E_x = C_1 \cos \omega t$
 $E_y = C_1 \cos(\omega t + \frac{\pi}{2})$
 $\psi = -C_1 \sin \omega t$

Circular polarization:

$$E_x(z,t) = C_1 \cos(\omega t - \beta z)$$

$$E_y(z,t) = C_1 \cos(\omega t - \beta z \pm \frac{\pi}{2})$$

90° phase shift

if $+\frac{\pi}{2}$ left-hand circular polarization

$-\frac{\pi}{2}$ right-hand circular polarization

2.5.3 Elliptical polarization

$$E_x(z) = c_{1x} e^{-j\beta z}$$

$$E_y(z) = c_{1y} e^{-j\beta z} e^{j\zeta}$$

$$\zeta = \begin{cases} -\frac{\pi}{2} & \text{RHCP} \\ +\frac{\pi}{2} & \text{LHCP} \\ 0 < \zeta < 90^\circ & \text{elliptical} \end{cases}$$

t=0 as a function of space

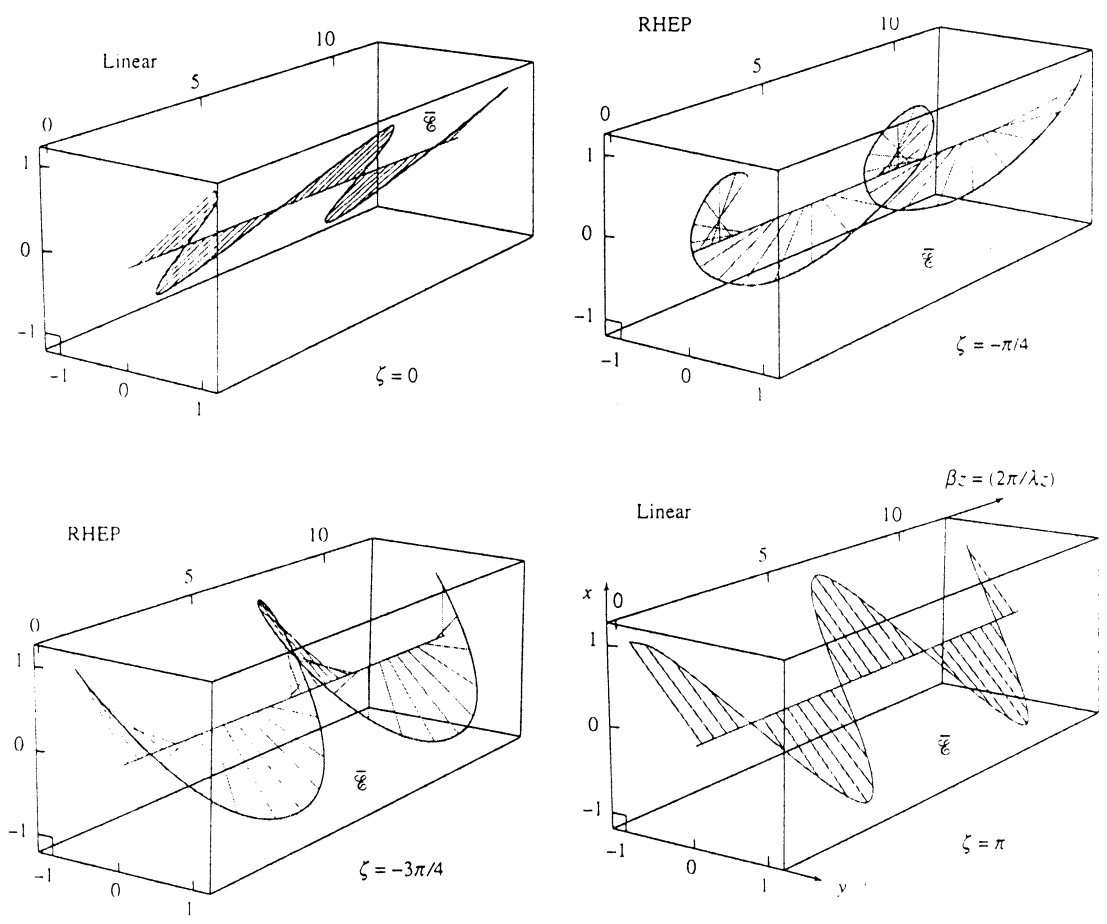
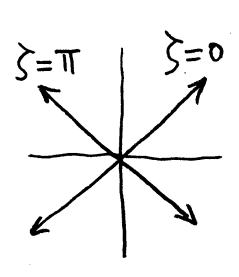

FIGURE 2.24. Polarization as a function of phase angle ζ . The electric field vectors at $t = 0$ and at different points in space for $C_{1x} = C_{1y}$ and for $\zeta = 0, -\pi/4, -3\pi/4$, and π .

Note that for $\zeta = \pm \frac{\pi}{2}$ this degenerates to circular polarization.

$\zeta = 0, \pi$ are linear (but inclined at 45°) polarization.



$\zeta = 0$		
wt	c_{1x}	c_{1y}
0	1	1
$\frac{\pi}{2}$	0	0

$\zeta = \pi$		
wt	c_{1x}	c_{1y}
0	1	-1
π	0	0

$\zeta = \frac{\pi}{4}$		
wt	c_{1x}	c_{1y}
0	1	$\frac{1}{\sqrt{2}}$
$\frac{\pi}{4}$	$\frac{1}{\sqrt{2}}$	0
$\frac{\pi}{2}$	0	$-\frac{1}{\sqrt{2}}$

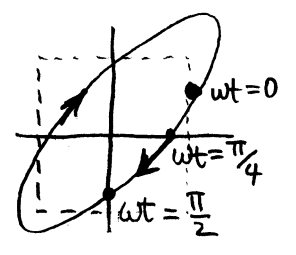

2.5.3 Elliptical polarization

$$E_x(z) = C_{1x} e^{-j\beta z}$$

$$E_y(z) = C_{1y} e^{-j\beta z} e^{j\zeta}$$

$$\zeta = \begin{cases} -\frac{\pi}{2} & \text{RHCP} \\ +\frac{\pi}{2} & \text{LHCP} \\ 0 < \zeta < 90^\circ & \text{elliptical} \end{cases}$$

t=0 as a function of space

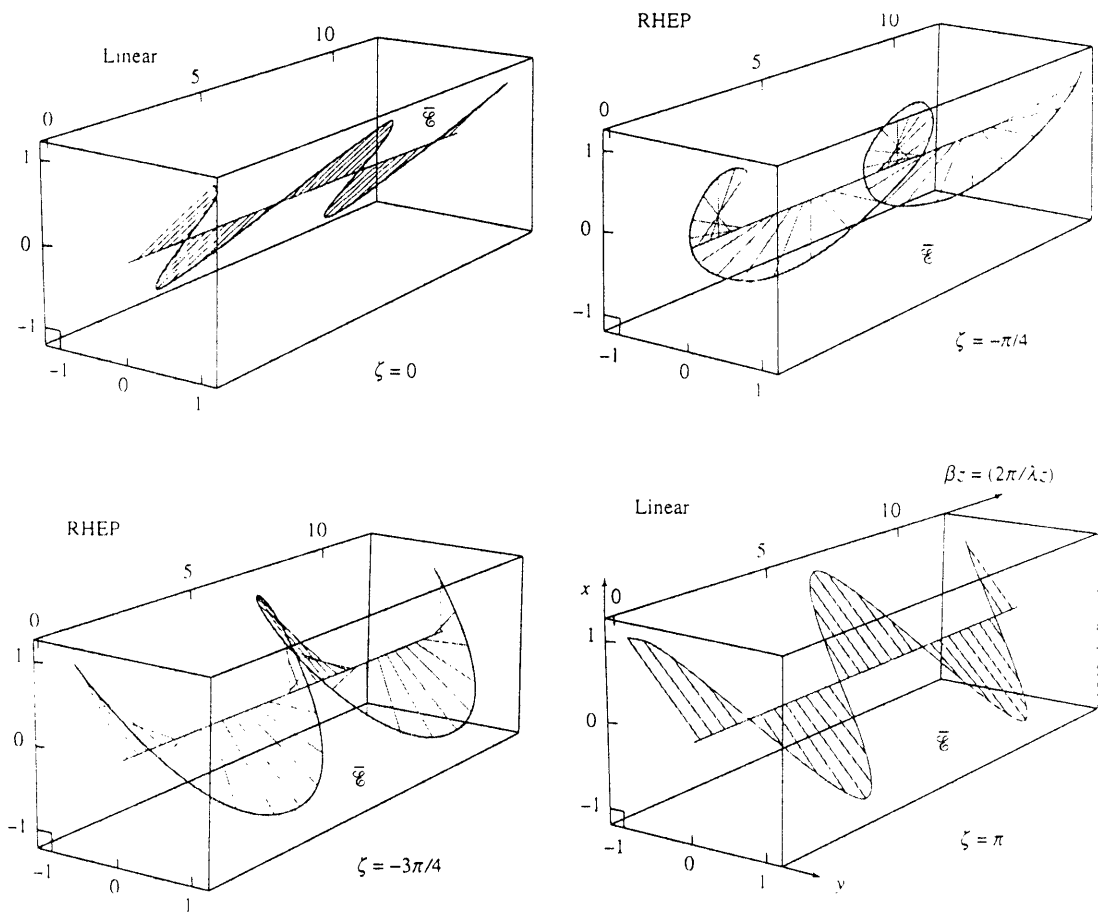

FIGURE 2.24. Polarization as a function of phase angle ζ . The electric field vectors at $t = 0$ and at different points in space for $C_{1x} = C_{1y}$ and for $\zeta = 0, -\pi/4, -3\pi/4$, and π .

Note that for $\zeta = \pm \frac{\pi}{2}$ this degenerates to circular polarization.
 $\zeta = 0, \pi$ are linear (but inclined at 45°) polarization.

Polarization ellipse (wave coming out of paper)

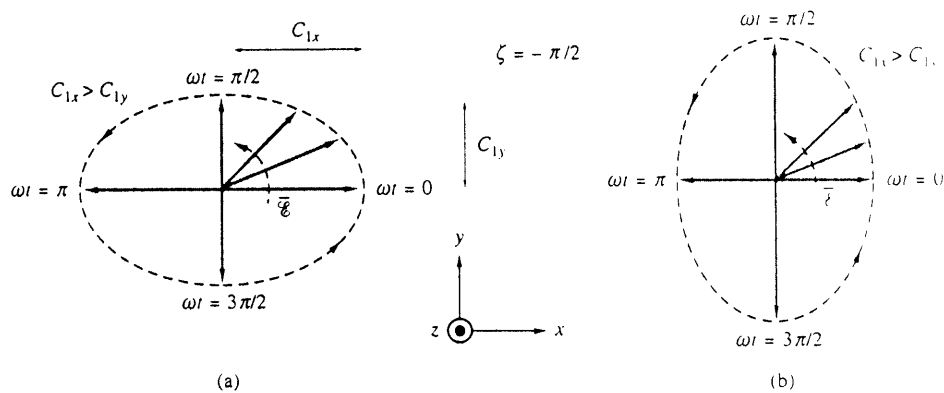

FIGURE 2.22. Elliptical polarization. The loci of the tip of the total electric field vector shown at the origin for an elliptically polarized wave propagating in the +z direction represented by [2.51] with $\zeta = -\pi/2$. (a) The major axis of the ellipse is along the x axis when $C_{1x} > C_{1y}$. (b) The major axis of the ellipse is along the y axis when $C_{1x} < C_{1y}$. As in the case of circular polarization, it can be shown using the right-hand rule that this wave is right-hand elliptically polarized (RHEP).

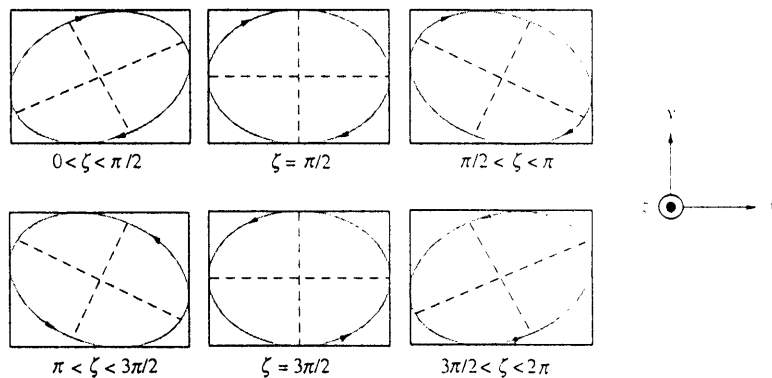

FIGURE 2.23. Elliptical polarization ellipses. The loci of the tip of the total electric field vector for an elliptically polarized wave as given by [2.51] for different ranges of values of ζ . Top panels are LHEP whereas the bottom panels are RHEP waves. The straight-line loci for the cases of $\zeta = 0$ and π , corresponding to linear polarization, are not shown.

The axes of the major/minor axes of the polarization ellipse will vary as a function of ζ

Example 2-21 $\underline{H}(x,t)$ traveling in $+\hat{x}$ direction

$$\underline{H}(x,t) = \hat{y} 8 \cos(\omega t - \beta x) + \hat{z} 12 \cos(\omega t - \beta x + 70^\circ)$$

The tilt angle is given by the ratio of the magnitudes which determines the bounding box

ωt	y	z
0	8	4.08
$\frac{\pi}{4}$	5.66	-5.04
$\frac{\pi}{2}$	0	-11.16

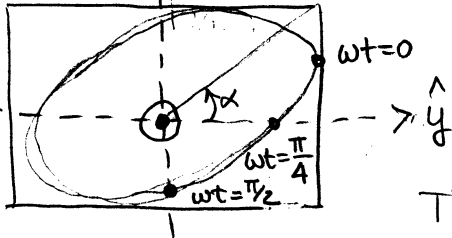

$$\tan \alpha = \frac{C_{1y}}{C_{1z}} = \frac{8}{12} = \frac{2}{3}$$

This DOES NOT correspond to the major-minor axes of the ellipse.

The major axis is at the angle ψ wrt the original axis.

Our book is a little vague about this angle ψ . According to Collin, Field Theory of Guided Waves, p. 72, we rotate the coordinate system about the propagation axis in a counterclockwise direction through an angle ψ .

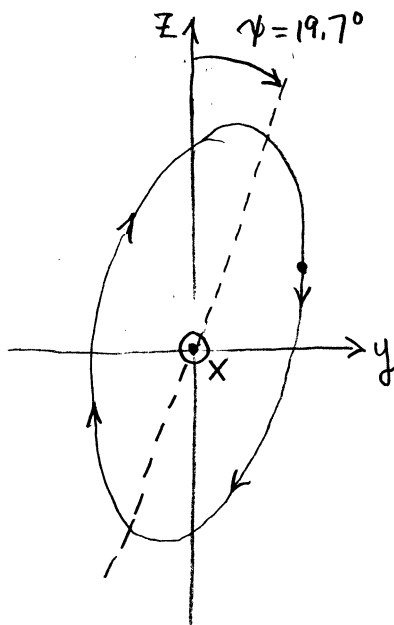

$$\text{where } \psi = \frac{1}{2} \tan^{-1}(\tan 2\alpha \cos \zeta)$$

ζ comes from the original phase shift

$$\zeta = 70^\circ \text{ or } \cos \zeta = 0.3420$$

we compute $\tan 2\alpha$ from $\tan \alpha$ by

$$\tan 2\alpha = \frac{2 \tan \alpha}{1 - \tan^2 \alpha} = \frac{2(\frac{2}{3})}{1 - (\frac{2}{3})^2} = 2.4$$

$$\psi = \frac{1}{2} \tan^{-1}(2.4 \times 0.3420) = 19.7^\circ$$

$$A_{x'} = C_{1x} \cos \psi + C_{1y} \sin \psi = 8 \cos 19.7 + 12 \sin 19.7 = 14$$

$$A_{y'} = -C_{1x} \sin \psi + C_{1y} \cos \psi = -8 \sin 19.7 + 12 \cos 19.7 = -3.49$$

Decomposition of an elliptically polarized wave into left & right hand circularly polarized waves

$$\underline{E}_1 = \hat{x} c_1 e^{-j\beta z} + \hat{y} j c_1 e^{-j\beta z} \quad \text{LHCP}$$

$$\underline{E}_2 = \hat{x} c_2 e^{-j\beta z} - \hat{y} j c_2 e^{-j\beta z} \quad \text{RHCP}$$

Sum is

$$\underline{E} = \hat{x} (c_1 + c_2) e^{-j\beta z} + \hat{y} j (c_1 - c_2) e^{-j\beta z}$$

This is for major & minor axes aligned with x-y axes.

Poynting Vector for elliptically polarized waves

$$\underline{S}_{av} = \frac{1}{2} \text{Re} \{ \underline{E} \times \underline{H}^* \}$$

$$\underline{S}_{av} = \hat{z} \frac{1}{2\eta} \{ c_{1x}^2 + c_{1y}^2 \}$$

2.6.1 Arbitrarily directed plane waves

$$\underline{E}(\underline{r}) = E_0 e^{-j\beta \hat{k} \cdot \underline{r}}$$

general solution

where $\underline{r} = \hat{x}x + \hat{y}y + \hat{z}z$

$$\underline{k} = \frac{\hat{x}\beta_x + \hat{y}\beta_y + \hat{z}\beta_z}{\omega\sqrt{\mu\epsilon}}$$

$$= \frac{\hat{x}\beta_x + \hat{y}\beta_y + \hat{z}\beta_z}{\sqrt{\beta_x^2 + \beta_y^2 + \beta_z^2}}$$

$$\underline{H}(\underline{r}) = \frac{1}{\eta} \hat{k} \times \underline{E}(\underline{r})$$

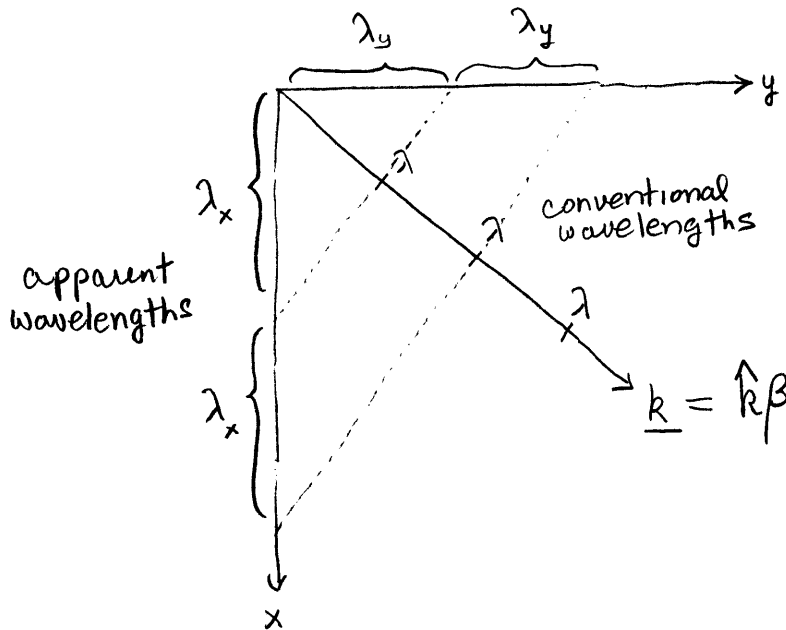
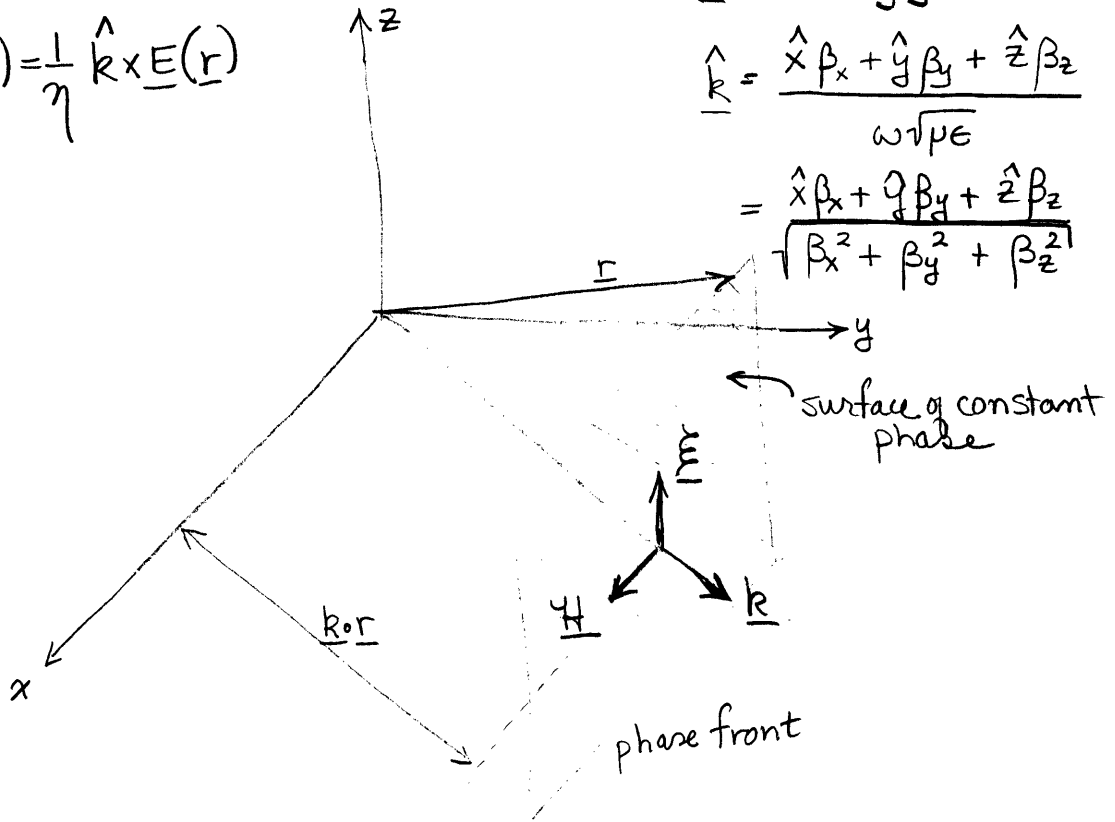

Radiation pressure (2.4.4)

Radiation pressure \triangleq force/unit area upon the material on which it is incident

Assume material completely absorbs incident EM energy.

$$\Delta \frac{q}{f} = \frac{\underline{S}_{AV} \Delta A \Delta t}{c} \quad \frac{\text{kg-m}}{\text{sec}}$$

where $\Delta \frac{q}{f}$ is the momentum delivered

\underline{S}_{AV} is the time average Poynting vector
(normally incident)

ΔA is the surface area

Δt is the time interval

c is the speed of light.

for a powerful (Terawatt) laser beam which is 0.1mm in diameter

$$\underline{S}_{AV} = \frac{10^{12}}{\pi (0.1 \times 10^{-3})^2} \cong 3.2 \times 10^{19} \frac{\text{W}}{\text{m}^2}$$

$$\underline{F}_{AV} = \frac{P_{AV}}{\Delta t} = \frac{\underline{S}_{AV} \Delta A}{c} \quad \text{newtons}$$

$$\text{For this laser beam} = \frac{10^{12} \text{ watts}}{\pi (0.1 \times 10^{-3})^2} \frac{\pi (0.1 \times 10^{-3})^2}{3 \times 10^8 \frac{\text{m}}{\text{sec}}}$$

$$= 3333 \frac{\text{watts-sec}}{\text{meter}} = 3333 \text{ Newtons?} \quad \text{units}$$

Crooke's radiometer

$$P_{AV} \text{ on a perfect reflector} = 2 P_{AV} \text{ on a perfect absorber}$$