

TWO-PORT NETWORKS

Up to now, all the circuits covered in this course have been real circuits without complex reactances and the gain was frequency independent. These models are useful for general applications, but are inadequate for r.f. and microwave applications. This material is a short introduction to a more generalized small-signal description of networks¹.

A two-port network is simply a network with four terminals which are arranged into pairs called ports. In general, there will be an input port and an output port for the networks we will be interested in. As shown below this network is characterized by input voltage v_I and current i_I while the output is characterized by voltage v_{II} and current i_{II} . It is common convention to denote these currents as positive going INTO the network. These sign conventions are summarized in the figure below.

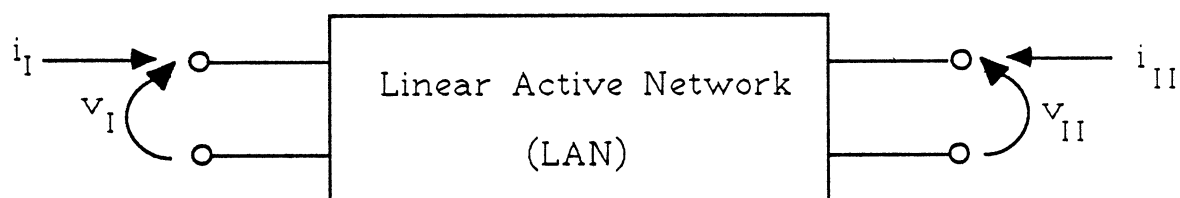

Most r.f. devices of interest have only three terminals, i.e. transistors; however, this merely means that our representation for these devices uses one device terminal as common to input and out. As we know from our study of amplifier topologies this makes perfect sense. After all, each amplifier has a common terminal which was denoted as common, i.e. common base, common collector, or common emitter.

There are four variables associated with any two port network as shown in the figure above, two voltages and two currents. These are our signals. From mathematics, any two of these four variables may be picked as independent variables with the remaining two being dependent variables. We will be using the

¹A more lengthy discussion of two-port networks (with extensive examples) can be found in Irwin, Introduction to Electrical Networks.

roman subscripts to represent total AC + DC parameters. In practice, two port parameters are usually used to describe only the ac variables and are denoted by Arabic subscripts, i.e. i_1 , v_1 , i_2 and v_2 , rather than the previously used roman subscripts. This means that we may write the terminal relationships for an ac two port network as

$$i_1 = y_{11}v_1 + y_{12}v_2 \quad (1a)$$

$$i_2 = y_{21}v_1 + y_{22}v_2 \quad (1b)$$

These relationships can be expressed compactly in matrix form as

$$\begin{bmatrix} i_1 \\ i_2 \end{bmatrix} = \begin{bmatrix} y_{11} & y_{12} \\ y_{21} & y_{22} \end{bmatrix} \begin{bmatrix} v_1 \\ v_2 \end{bmatrix} \quad (2)$$

leading to the name "matrix parameters" to describe this type of two-port representation.

Before relating matrix parameters to transistor parameters let us consider the nature of the relationship between independent and dependent variables. For purposes of illustration let us continue with i_1 and i_2 as the dependent variables. However, in terms of real world parameters i_1 and i_2 are small signal currents. Let us write the total (ac + dc) terminal variables as small letters with Roman subscripts, i.e. i_I , i_{II} , v_I and v_{II} . These may be expressed in terms of the previously defined small signal voltages and currents i_1 , i_2 , v_1 and v_2 and dc voltages and currents I_1 , I_2 , V_1 and V_2 .

$$i_I = I_1 + i_1 \quad (3a)$$

$$i_{II} = I_2 + i_2 \quad (3b)$$

In both equations the first term on the right hand side is the steady state (dc) term and the second is the small signal (ac) term which is assumed to fluctuate about the steady state value.

Note that our earlier matrix formulas are in terms of small signal parameters only. In general we can write the input/output relationships for the total (ac+dc) variables as

$$i_I = f(v_I, v_{II}) \quad (4a)$$

$$i_{II} = g(v_I, v_{II}) \quad (4b)$$

We can recall the Taylor series expansion

$$f(x+h) = f(x) + h \frac{\partial f(x)}{\partial h} + \dots \quad (5)$$

where $h \ll x$ and perform a Taylor series expansion of f and g in our expressions for i_I and i_{II}

$$i_I = f_0(v_I, v_{II}) + (v_I - v_{I,0}) \frac{\partial f_0(v_I, v_{II})}{\partial v_I} + (v_{II} - v_{II,0}) \frac{\partial f_0(v_I, v_{II})}{\partial v_{II}} \quad (6a)$$

$$i_{II} = \overset{g}{g}_0(v_I, v_{II}) + (v_I - v_{I,0}) \frac{\partial g_0(v_I, v_{II})}{\partial v_I} + (v_{II} - v_{II,0}) \frac{\partial g_0(v_I, v_{II})}{\partial v_{II}} \quad (6b)$$

where the subscript "0" indicates the initial value, i.e. the dc value about which we are going to do a small signal expansion. This looks very formidable but let us examine the terms in light of our definitions of total, dc and ac (or small signal) terminal parameters. $i_I - f_0(v_I, v_{II})$ is simply the total terminal variable minus the dc terminal variable I_1 , or mathematically

$$i_I - f_0(v_I, v_{II}) = i_I - I_1 = i_1 \quad (7a)$$

This can be repeated for the output terminal, or port, to give

$$i_{II} - g_0(v_I, v_{II}) = i_{II} - I_{II} = i_2 \quad (7b)$$

These expressions can be substituted into the small signal expansions (5) to yield

$$i_1 = (v_I - v_{I,0}) \frac{\partial f_0(v_I, v_{II})}{\partial v_I} + (v_{II} - v_{II,0}) \frac{\partial f_0(v_I, v_{II})}{\partial v_{II}} \quad (8a)$$

$$i_2 = (v_I - v_{I,0}) \frac{\partial g_0(v_I, v_{II})}{\partial v_I} + (v_{II} - v_{II,0}) \frac{\partial g_0(v_I, v_{II})}{\partial v_{II}} \quad (8b)$$

The above expressions can be further simplified if we recognize $(v_I - v_{I,0})$ and $(v_{II} - v_{II,0})$ as expressions for the small signal parameters v_1 and v_2 respectively. This follows from the definitions of parameters in Equation (3). Simplifying Equation (8) we get

$$i_1 = v_1 \frac{\partial f_0(v_I, v_{II})}{\partial v_I} + v_2 \frac{\partial f_0(v_I, v_{II})}{\partial v_{II}} \quad (9a)$$

$$i_2 = v_1 \frac{\partial g_0(v_I, v_{II})}{\partial v_I} + v_2 \frac{\partial g_0(v_I, v_{II})}{\partial v_{II}} \quad (9b)$$

This is exactly the form of our original matrix equation, Equation (2), provided that we recognize the derivatives as the y-matrix parameters. Making the associations we have

$$y_{11} = \frac{\partial f_0(v_I, v_{II})}{\partial v_I} \quad (10a)$$

$$y_{12} = \frac{\partial f_0(v_I, v_{II})}{\partial v_{II}} \quad (10b)$$

$$y_{21} = \frac{\partial g_0(v_I, v_{II})}{\partial v_I} \quad (10c)$$

$$y_{22} = \frac{\partial g_0(v_I, v_{II})}{\partial v_{II}} \quad (10d)$$

As can be seen above the y matrix parameters are simply the partial derivatives of f and g with respect to the independent variables v_{II} and v_I evaluated at the initial point (V_I, V_{II}) .

Referring to Equation (1) we see that each y-matrix parameter converts a voltage to a current; hence, each y-matrix element must have the units of $1/\Omega$, or mhos. This makes each y-matrix element an admittance which is usually denoted by a "y" and is the reason why this particular formulation is called a y-matrix. The y-parameters are particularly useful for r.f. circuits. Up to this point the two port parameters have been treated as mathematical abstractions. However, two port parameters are extremely easy to measure in the real world and can be easily manipulated to give amplifier gain, etc.

In Equation (1) we see that if $v_2 = 0$, Equation (1) reduces to

$$i_1 = y_{11}v_1 \qquad i_2 = y_{21}v_1$$

By simply providing a short across the output terminals and measuring the currents i_1 and i_2 and the input voltage v_1 we can measure two of the four y-matrix parameters, or y-parameters for short.

$$y_{11} = \frac{i_1}{v_1} \qquad y_{21} = \frac{i_2}{v_1}$$

y_{11} is called the input admittance (output port short-circuited) and y_{21} is called the forward transconductance ratio (output port short-circuited). Similar expressions can be derived for y_{12} and y_{22} provided we short-circuit the input port instead. The results of this are

$$y_{12} = \frac{i_1}{v_2} \qquad y_{22} = \frac{i_2}{v_2}$$

where we can now identify y_{12} as the reverse transconductance ratio (input port short-circuited) and y_{22} as the output admittance (input port short-circuited). In practice, y_{11} , y_{12} , y_{21} and y_{22} are determined by measuring the terminal parameters with the input and output ports alternately shorted.

Before continuing with more general two port networks we should attempt to relate what we have just done to what we know of circuits. In general, most amplifiers and electrical networks have three terminals and are characterized by three variables. (See the previous discussion of transistor characteristics and biasing.) By choosing one terminal to be common to the input and output as shown below we can put these familiar amplifiers into a two port formalism for sophisticated network analysis. This means that the y -parameters just discussed can be measured by simply sequentially putting an ac short (a capacitor) across the amplifier input and output terminals of a network and measuring the resulting terminal voltages and currents. Careful attention must be given to the fact that the currents were defined with their sign as being positive going into the two port and negative if coming from the two port. The real beauty of the two port formalism is that the parameters are very simple to measure and the various network parameters such as voltage gain, input impedance, Miller effect, etc are simply described using the two port parameters. As we shall see in later sections the y -parameters are a single case of a more general formalism which we shall exploit heavily in our study of r.f. circuits.

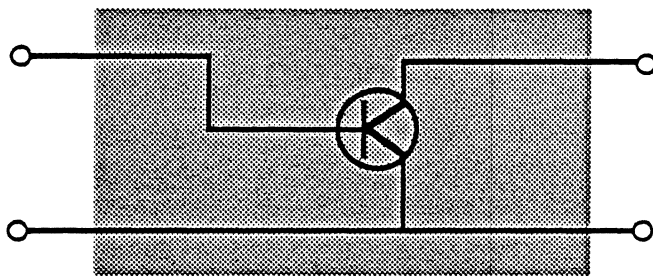

Three-terminal two port network

MATRIX PARAMETER DEFINITIONS AND CONVERSIONS

During the remainder of the course it will often be necessary to convert a problem specified in one set of two-port matrix parameters to another set.

The two-port h parameters are defined below

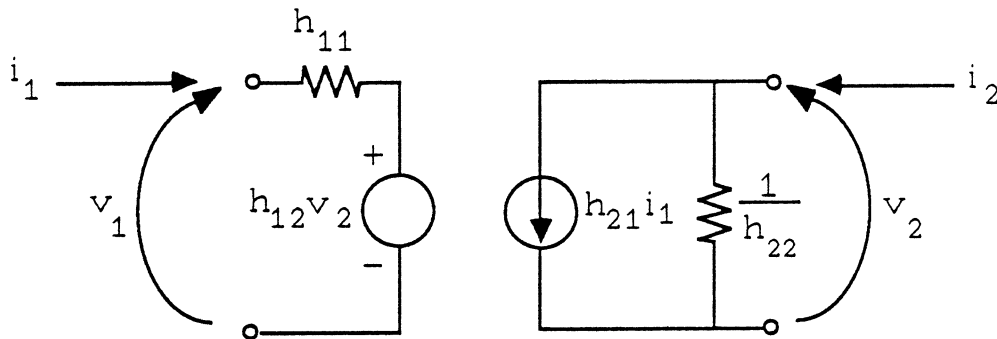

The corresponding terminal equations are

$$v_1 = h_{11}i_1 + h_{12}v_2$$

$$i_2 = h_{21}i_1 + h_{22}v_2$$

The two-port y parameters are defined below

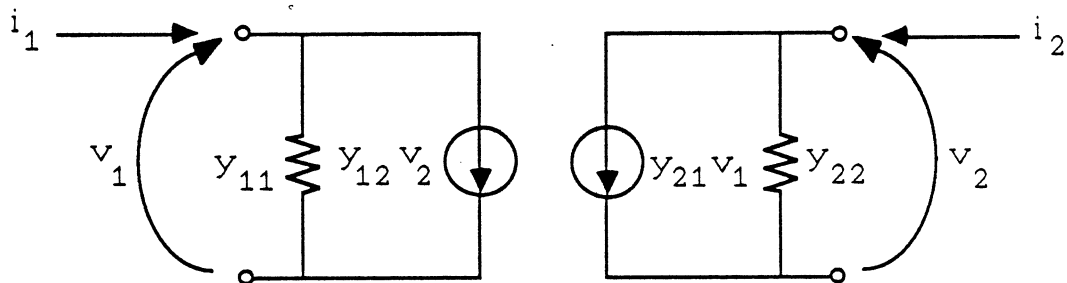

The corresponding terminal equations are

$$i_1 = y_{11}v_1 + y_{12}v_2$$

$$i_2 = y_{21}v_1 + y_{22}v_2$$



The two-port z parameters are defined below

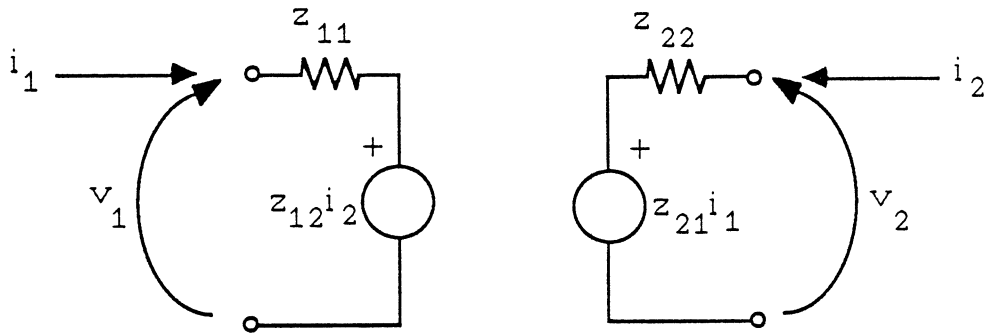

The corresponding terminal equations are

$$v_1 = z_{11}i_1 + z_{12}i_2$$

$$v_2 = z_{21}i_1 + z_{22}i_2$$

The two-port g parameters are defined below

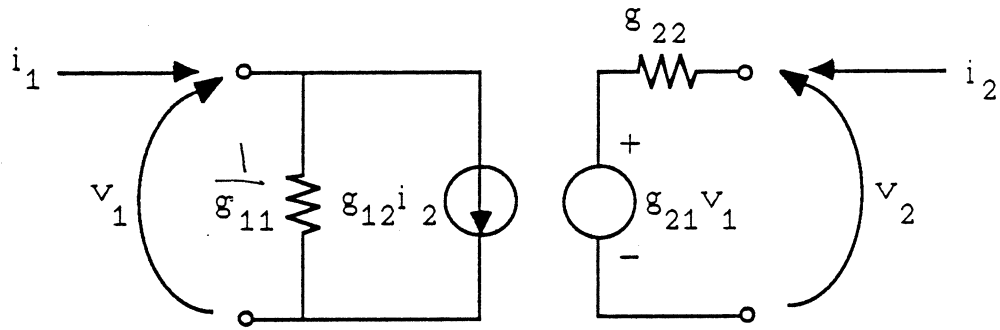

The corresponding terminal equations are

$$i_1 = g_{11}v_1 + g_{12}i_2$$

$$v_2 = g_{21}v_1 + g_{22}i_2$$

The so-called T, or ABCD, two-port parameters are defined below

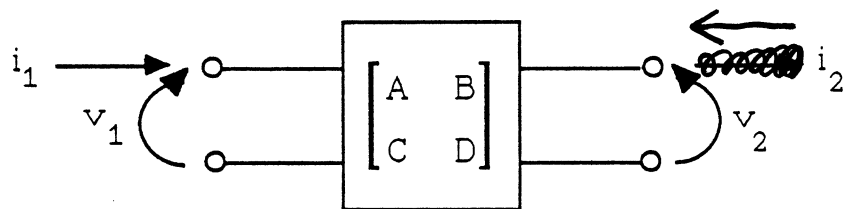



NOTE THAT THE ABCD-PARAMETERS DEFINE i_2 IN THE OPPOSITE DIRECTION TO ALL OTHER MATRIX PARAMETERS. The corresponding two-port terminal equations are

$$v_1 = Av_2 - Bi_2 \qquad \underline{i_1} = Cv_2 - Di_2$$

and, in matrix form, as

$$\begin{bmatrix} v_1 \\ i_1 \end{bmatrix} = \begin{bmatrix} A & B \\ C & D \end{bmatrix} \begin{bmatrix} v_2 \\ -i_2 \end{bmatrix}$$

where the negative sign for i_2 must be explicitly shown.

To summarize the definitions above, the two-port parameter matrices are

$$[z] = \begin{bmatrix} z_{11} & z_{12} \\ z_{21} & z_{22} \end{bmatrix} \qquad [y] = \begin{bmatrix} y_{11} & y_{12} \\ y_{21} & y_{22} \end{bmatrix}$$

$$[h] = \begin{bmatrix} h_{11} & h_{12} \\ h_{21} & h_{22} \end{bmatrix} \qquad [T] = \begin{bmatrix} A & B \\ C & D \end{bmatrix}$$

It is very handy to be able to convert from one set of matrix parameters to another for expediency in combining networks or analyzing networks. To convert between any two sets of matrix parameters use the table shown on the following page, MATRICES IN THE SAME ROW OR COLUMN ARE EQUIVALENT. For example

$$\begin{bmatrix} z_{11} & z_{12} \\ z_{21} & z_{22} \end{bmatrix} = \begin{bmatrix} \frac{\Delta_h}{h_{22}} & \frac{h_{12}}{h_{22}} \\ -\frac{h_{21}}{h_{22}} & \frac{1}{h_{22}} \end{bmatrix}$$

The matrix elements are then explicitly equivalent, i. e.

$$z_{12} = \frac{h_{12}}{h_{22}} \quad \text{etc.}$$

	[z]	[y]	[T]	[h]
[z]	$\begin{bmatrix} z_{11} & z_{12} \\ z_{21} & z_{22} \end{bmatrix}$	$\begin{bmatrix} \frac{y_{22}}{\Delta_y} & -\frac{y_{12}}{\Delta_y} \\ -\frac{y_{21}}{\Delta_y} & \frac{y_{11}}{\Delta_y} \end{bmatrix}$	$\begin{bmatrix} \frac{A}{C} & \frac{\Delta_T}{C} \\ \frac{1}{C} & \frac{D}{C} \end{bmatrix}$	$\begin{bmatrix} \frac{\Delta_h}{h_{22}} & \frac{h_{12}}{h_{22}} \\ -\frac{h_{21}}{h_{22}} & \frac{1}{h_{22}} \end{bmatrix}$
[y]	$\begin{bmatrix} \frac{z_{22}}{\Delta_z} & -\frac{z_{12}}{\Delta_z} \\ -\frac{z_{21}}{\Delta_z} & \frac{z_{11}}{\Delta_z} \end{bmatrix}$	$\begin{bmatrix} y_{11} & y_{12} \\ y_{21} & y_{22} \end{bmatrix}$	$\begin{bmatrix} \frac{D}{B} & -\frac{\Delta_T}{B} \\ -\frac{1}{B} & \frac{A}{B} \end{bmatrix}$	$\begin{bmatrix} \frac{1}{h_{11}} & -\frac{h_{12}}{h_{11}} \\ \frac{h_{21}}{h_{11}} & \frac{\Delta_h}{h_{11}} \end{bmatrix}$
[T]	$\begin{bmatrix} \frac{z_{11}}{z_{21}} & \frac{\Delta_z}{z_{21}} \\ \frac{1}{z_{21}} & \frac{z_{22}}{z_{21}} \end{bmatrix}$	$\begin{bmatrix} -\frac{y_{22}}{y_{21}} & -\frac{1}{y_{21}} \\ -\frac{\Delta_y}{y_{21}} & -\frac{y_{11}}{y_{21}} \end{bmatrix}$	$\begin{bmatrix} A & B \\ C & D \end{bmatrix}$	$\begin{bmatrix} -\frac{\Delta_h}{h_{21}} & -\frac{h_{11}}{h_{21}} \\ -\frac{h_{22}}{h_{21}} & -\frac{1}{h_{21}} \end{bmatrix}$
[h]	$\begin{bmatrix} \frac{\Delta_z}{z_{22}} & \frac{z_{12}}{z_{22}} \\ -\frac{z_{21}}{z_{22}} & \frac{1}{z_{22}} \end{bmatrix}$	$\begin{bmatrix} \frac{1}{y_{11}} & -\frac{y_{12}}{y_{11}} \\ \frac{y_{21}}{y_{11}} & \frac{\Delta_y}{y_{11}} \end{bmatrix}$	$\begin{bmatrix} \frac{B}{D} & \frac{\Delta_T}{D} \\ -\frac{1}{D} & \frac{C}{D} \end{bmatrix}$	$\begin{bmatrix} h_{11} & h_{12} \\ h_{21} & h_{22} \end{bmatrix}$

$$\Delta_y = y_{11}y_{22} - y_{12}y_{21}$$

$$\Delta_z = z_{11}z_{22} - z_{12}z_{21}$$

$$\Delta_h = h_{11}h_{22} - h_{12}h_{21}$$

$$\Delta_T = AD - BC$$

MATRIX CONVERSIONS

To show how the conversion table on the previous page was constructed consider the transformation from z-parameters to y-parameters as an example.

In matrix form the y-parameter equations are

$$\begin{bmatrix} i_1 \\ i_2 \end{bmatrix} = \begin{bmatrix} y_{11} & y_{12} \\ y_{21} & y_{22} \end{bmatrix} \begin{bmatrix} v_1 \\ v_2 \end{bmatrix}$$

Similarly, for z-parameters

$$\begin{bmatrix} v_1 \\ v_2 \end{bmatrix} = \begin{bmatrix} z_{11} & z_{12} \\ z_{21} & z_{22} \end{bmatrix} \begin{bmatrix} i_1 \\ i_2 \end{bmatrix}$$

Substituting the second set of matrices into the first set

$$\begin{bmatrix} i_1 \\ i_2 \end{bmatrix} = \begin{bmatrix} y_{11} & y_{12} \\ y_{21} & y_{22} \end{bmatrix} \begin{bmatrix} z_{11} & z_{12} \\ z_{21} & z_{22} \end{bmatrix} \begin{bmatrix} i_1 \\ i_2 \end{bmatrix}$$

One recognizes that the product of the [y] and [z] matrices must be the identity matrix since the current matrices MUST be identical, i. e.

$$\begin{bmatrix} y_{11} & y_{12} \\ y_{21} & y_{22} \end{bmatrix} \begin{bmatrix} z_{11} & z_{12} \\ z_{21} & z_{22} \end{bmatrix} = \begin{bmatrix} 1 & 0 \\ 0 & 1 \end{bmatrix}$$

Multiplying the matrices and equating the resulting matrix elements with the corresponding elements of the identity matrix we get the following set of simultaneous equations which can be solved for the y-parameters in terms of the z-parameters.

$$y_{11}z_{11} + y_{12}z_{21} = 1$$

$$y_{11}z_{12} + y_{12}z_{22} = 0$$

$$y_{21}z_{11} + y_{22}z_{21} = 0$$

$$y_{21}z_{12} + y_{22}z_{22} = 1$$

Working with the off-diagonal equations (the zero elements)

$$y_{21}z_{11} = -y_{22}z_{21} \quad \text{or} \quad y_{21} = -y_{22} \frac{z_{21}}{z_{11}}$$

$$y_{12}z_{22} = -y_{11}z_{12} \quad \text{or} \quad y_{12} = -y_{11} \frac{z_{12}}{z_{22}}$$

Working with the diagonal expressions (the 1's)

$$y_{11}z_{11} + \left(-y_{11} \frac{z_{12}}{z_{22}}\right) z_{21} = 1$$

$$y_{11} \left(z_{11} - \frac{z_{12}z_{21}}{z_{22}}\right) = 1$$

$$y_{11} \left(\frac{z_{11}z_{22} - z_{12}z_{21}}{z_{22}}\right) = 1$$

$$y_{11} \left(\frac{\Delta_z}{z_{22}}\right) = 1$$

$$y_{11} = \frac{z_{22}}{\Delta_z}$$

and

$$\left(-y_{22} \frac{z_{21}}{z_{11}}\right) z_{12} + y_{22}z_{22} = 1$$

$$y_{22} \left(z_{22} - \frac{z_{12}z_{21}}{z_{11}}\right) = 1$$

$$y_{22} \left(\frac{z_{11}z_{22} - z_{12}z_{21}}{z_{11}} \right) = 1$$

$$y_{22} \left(\frac{\Delta_z}{z_{11}} \right) = 1 \qquad y_{11} = \frac{z_{11}}{\Delta_z}$$

Substituting these results back into our expressions for y_{12} and y_{21}

$$y_{21} = -y_{22} \frac{z_{21}}{z_{11}} = - \left(\frac{z_{11}}{\Delta_z} \right) \frac{z_{21}}{z_{11}} = - \frac{z_{21}}{\Delta_z}$$

and

$$y_{12} = -y_{11} \frac{z_{12}}{z_{22}} = - \left(\frac{z_{22}}{\Delta_z} \right) \frac{z_{12}}{z_{22}} = - \frac{z_{12}}{\Delta_z}$$

which completes our results. Note that these expressions are identical to those of the second column of the first row of the matrix conversion table.