

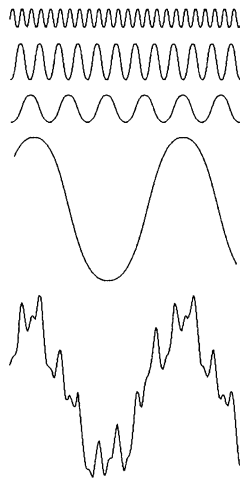

Chapter 4 Image Enhancement in the Frequency Domain



} Sum of above four functions gives this noisy looking signal.

FIGURE 4.1 The function at the bottom is the sum of the four functions above it. Fourier's idea in 1807 that periodic functions could be represented as a weighted sum of sines and cosines was met with skepticism.

© 2002 R. C. Gonzalez & R. E. Woods

1-D Fourier transform:

$$F(u) = \int_{-\infty}^{\infty} f(x) e^{-j2\pi ux} dx$$

$$f(x) = \int_{-\infty}^{+\infty} F(u) e^{j2\pi ux} du$$

2-D Fourier transform

$$F(u, v) = \int_{-\infty}^{\infty} \int_{-\infty}^{+\infty} f(x, y) e^{-j2\pi(ux+vy)} dx dy$$

$$f(x, y) = \int_{-\infty}^{+\infty} \int_{-\infty}^{+\infty} F(u, v) e^{+j2\pi(ux+vy)} du dv$$

Discrete Fourier Transform

$$F(u) = \frac{1}{M} \sum_{x=0}^{M-1} f(x) e^{-j \frac{2\pi ux}{M}} \quad u=0, 1, \dots, M-1$$

$$f(x) = \sum_{u=0}^{M-1} F(u) e^{j \frac{2\pi ux}{M}} \quad x=0, 1, \dots, M-1$$



Chapter 4 Image Enhancement in the Frequency Domain

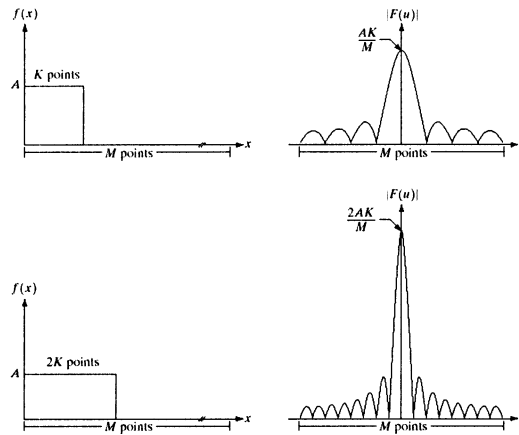

a b
c d
FIGURE 4.2 (a) A discrete function of M points and (b) its Fourier spectrum. (c) A discrete function with twice the number of nonzero points, and (d) its Fourier spectrum.

© 2002 R. C. Gonzalez & R. E. Woods

For above figure $A=1$
 $m=1024$
 $K=8$

As the width of the function increased by 2 the area under the curve increases by 2 and the peak value increases by 2. Also note that the number of zero's in the transform also increases by 2.

In the future,

$$f(x) \triangleq f(x_0 + x \Delta x)$$

$$F(u) \triangleq F(u \Delta u) \text{ for } u=0, 1, 2, \dots, M-1$$

$$\Delta u = \frac{1}{m \Delta x}$$



Chapter 4
Image Enhancement in the
Frequency Domain

FIGURE 4.3
(a) Image of a 20×40 white rectangle on a black background of size 512×512 pixels.
(b) Centered Fourier spectrum shown after application of the log transformation given in Eq. (3.2-2). Compare with Fig. 4.2.

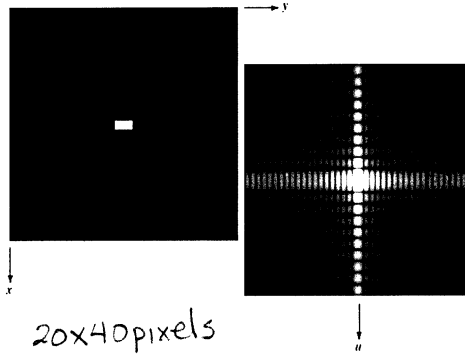

centered
probably $|F(u,v)|$
 $0.5 \log(1+r)$ transform

Note twice as many zeros in u as compared to v .

© 2002 R. C. Gonzalez & R. E. Woods

2-D DFT

$$F(u,v) = \frac{1}{MN} \sum_{x=0}^{m-1} \sum_{y=0}^{N-1} f(x,y) e^{-j2\pi \left(\frac{ux}{M} + \frac{vy}{N} \right)}$$

$$f(x,y) = \sum_{u=0}^{m-1} \sum_{v=0}^{N-1} F(u,v) e^{+j2\pi \left(\frac{ux}{M} + \frac{vy}{N} \right)}$$

Fourier spectrum $|F(u,v)| = \sqrt{R^2(u,v) + I^2(u,v)}$

phase angle $\phi(u,v) = \tan^{-1} \left[\frac{I(u,v)}{R(u,v)} \right]$

power spectra $P(u,v) = |F(u,v)|^2 = R^2(u,v) + I^2(u,v)$

Multiply input image by $(-1)^{x+y}$ to center transform.

$$\mathcal{F} \left[f(x,y) (-1)^{x+y} \right] = F \left(u - \frac{M}{2}, v - \frac{N}{2} \right)$$

i.e. $F(0,0)$ is located at $u = \frac{M}{2}, v = \frac{N}{2}$

GWE 4.1

$$F(u, v) = \sum_{x=0}^{M-1} \sum_{y=0}^{N-1} f(x, y) e^{-j2\pi \left(\frac{ux}{M} + \frac{vy}{N} \right)}$$

where u, v are frequency variables

$$f(x, y) = \frac{1}{MN} \sum_{u=0}^{M-1} \sum_{v=0}^{N-1} \underbrace{F(u, v)}_{\text{Fourier coefficients}} e^{+j2\pi \left(\frac{ux}{M} + \frac{vy}{N} \right)}$$

If $f(x, y)$ is real $F(u, v) = F^*(-u, -v)$

$$\Rightarrow |F(u, v)| = |F(-u, -v)|$$

By substitution

$$F(u, v) = F(u+M, v) = F(u, v+N) = F(u+M, v+N)$$

\Rightarrow infinitely periodic in u & v

From the inverse DFT $f(x, y)$ is periodic in x and y .

$$f(x, y) = f(x+M, y) = f(x, y+N) = f(x+M, y+N)$$

Some properties of the 2-D Fourier Transform

Translation

$$f(x, y) e^{j2\pi \left(\frac{u_0 x}{M} + \frac{v_0 y}{N} \right)} \Leftrightarrow F(u - u_0, v - v_0)$$

$$f(x - x_0, y - y_0) \Leftrightarrow F(u, v) e^{-j2\pi \left(\frac{u_0 x}{M} + \frac{v_0 y}{N} \right)}$$

incidentally if we put $u_0 = \frac{M}{2}$ and $v_0 = \frac{N}{2}$ we get

$F(u - \frac{M}{2}, v - \frac{N}{2})$ and

$$e^{j2\pi \left(\frac{u_0 x}{M} + \frac{v_0 y}{N} \right)} = e^{j2\pi \left(\frac{x}{2} + \frac{y}{2} \right)} = e^{j\pi(x+y)} = (-1)^{x+y}$$



MATLAB/Image Processing Toolbox

MATLAB Fourier transforms

```
>> f=imread('Figure_Rectangle.jpg'); % load in spatial rectangle
>> F=fft2(f); % do 2D FFT
>> S=abs(F); % determine magnitude for disp
>> imshow(S, [ ]) % shows in four corners of displa
>> Fc=fftshift(F); % shift FFT to center
>> imshow(abs(Fc), [ ]); % show magnitude of FFT in cen
```

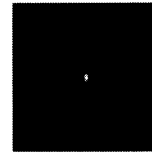

```
% much tougher to do display transform
>> g=im2unit8(mat2gray(log(1+double(f))));
>> imshow(g)
% double converts the image to double precision floating point
% mat2gray brings the values to the range [0,1]
% im2unit8 brings the values back to the range [0,255]
```

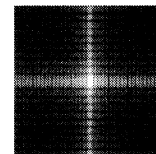

```
% general log transform
>> g=im2unit8(mat2gray(c*log(1+double(f))));
```

SEE GWE, Section 4.2 Computing and Visualizing the 2-D DFT in MATLAB
GWE, Section 3.2.2 Logarithmic and Contrast Stretching Transformations



Chapter 4 Image Enhancement in the Frequency Domain



a
b
FIGURE 4.4
(a) SEM image of a damaged integrated circuit. (b) Fourier spectrum of (a). (Original image courtesy of Dr. J. M. Hudak, Brockhouse Institute for Materials Research, McMaster University, Hamilton, Ontario, Canada.)

© 2002 R. C. Gonzalez & R. E. Woods

value $F(0,0) = \frac{1}{MN} \sum_{x=0}^{M-1} \sum_{y=0}^{N-1} f(x,y)$ which is the average image intensity

Note that $|F(u,v)| = |F(-u,-v)|$

In this figure the strong axes of $|F(u,v)|$ correspond to the approximate $\pm 45^\circ$ edges in the SEM image.

The angle of the white oxide extrusions wrt horizontal roughly corresponds to the short white off-center line in the transform.



Chapter 4 Image Enhancement in the Frequency Domain

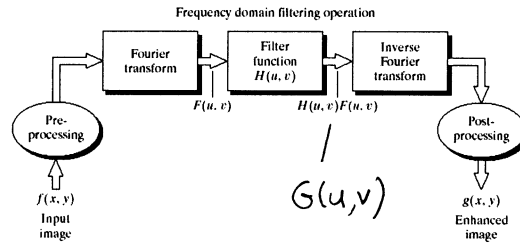

FIGURE 4.5 Basic steps for filtering in the frequency domain.

© 2002 R. C. Gonzalez & R. E. Woods

Preprocessing examples

- $(-1)^{x+y}$ multiplication
- cropping image to even dimension
- gray level scaling
- conversion to floating point

H is known as a zero-phase filter. In general, filters for imaging are real and do not change the phase of $F(u,v)$

Notch filter

$$H(u,v) = \begin{cases} 0 & \text{if } (u,v) = \left(\frac{M}{2}, \frac{N}{2}\right) \\ 1 & \text{otherwise} \end{cases}$$

Such a filter is called a notch filter because it removes only $F(0,0)$ which is the average value of the image.



Chapter 4 Image Enhancement in the Frequency Domain

FIGURE 4.6
Result of filtering
the image in
Fig. 4.4(a) with a
notch filter that
set to 0 the
 $F(0, 0)$ term in
the Fourier
transform.

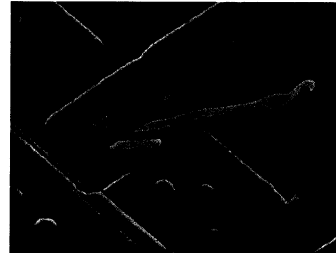

© 2002 R. C. Gonzalez & R. E. Woods

This is an example of a displayed image after $F(0,0)$ was removed by a notch filter.

Since a display cannot show negative values the image has been shifted so that the most negative value corresponds to zero, i.e. black.

Other kinds of filters:

low pass - attenuates high frequencies while passing low frequencies which come from the large, smooth areas in the image. will show less gray scale variation.

high-pass - attenuates low frequencies while passing high frequencies which come from image detail such as edges and noise



Chapter 4 Image Enhancement in the Frequency Domain

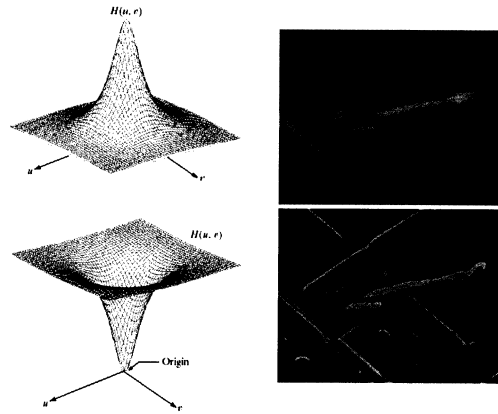

a b
c d
FIGURE 4.7 (a) A two-dimensional lowpass filter function. (b) Result of lowpass filtering the image in Fig. 4.4(a).
(c) A two-dimensional highpass filter function. (d) Result of highpass filtering the image in Fig. 4.4(a).

© 2002 R. C. Gonzalez & R. E. Woods

- (a) blurred image with high frequency detail missing due to low-pass filter
- (b) high-pass filter. sharp image with prominent edge information dark because negative information not being shown.



Chapter 4 Image Enhancement in the Frequency Domain

FIGURE 4.8
Result of highpass filtering the image in Fig. 4.4(a) with the filter in Fig. 4.7(c), modified by adding a constant of one-half the filter height to the filter function. Compare with Fig. 4.4(a).

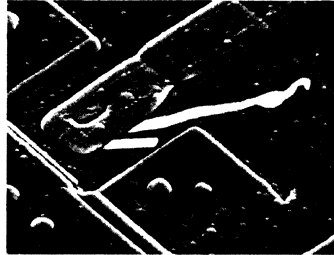

Result of adding a constant to the high-pass filtered image. Adding a constant shifts previously negative values from black into perceivable gray scale.



Chapter 4
Image Enhancement in the
Frequency Domain

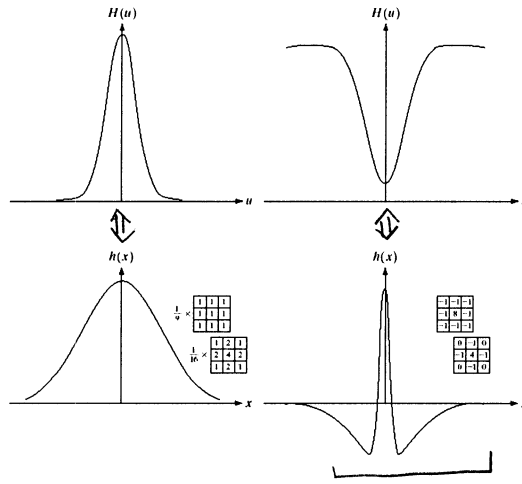

FIGURE 4.9
(a) Gaussian frequency domain lowpass filter.
(b) Gaussian frequency domain highpass filter.
(c) Corresponding lowpass spatial filter.
(d) Corresponding highpass spatial filter. The masks shown are used in Chapter 3 for lowpass and highpass filtering.

This is a difference of Gaussians

The Gaussian filter can be shown to be an optimal filter under certain conditions and has the property that both the forward and reverse transform of a Gaussian is a Gaussian.

$$\left. \begin{aligned}
 h(x) &= \sqrt{2\pi} \sigma A e^{-2\pi^2 \sigma^2 x^2} \\
 H(u) &= A e^{-\frac{u^2}{2\sigma^2}}
 \end{aligned} \right\} \begin{array}{l} \text{both real} \\ \text{construct using} \\ \text{Pascal's triangle} \end{array}$$

$$\frac{1}{9} \begin{bmatrix} 1 & 1 & 1 \\ 1 & 1 & 1 \\ 1 & 1 & 1 \end{bmatrix}$$

low-pass

$$\frac{1}{16} \begin{bmatrix} 1 & 2 & 1 \\ 2 & 4 & 2 \\ 1 & 2 & 1 \end{bmatrix}$$

weighted average filter from 3.6.1

$$\begin{array}{ccccccc}
 & & & & 1 & & & & \\
 & & & & 1 & 1 & & & \\
 & & & 1 & 2 & 1 & & & \\
 & & 1 & 3 & 3 & 1 & & & \\
 1 & 4 & 6 & 4 & 1 & & & &
 \end{array}$$

Difference of Gaussians

$$h(x) = \sqrt{2\pi} \sigma_1 A e^{-2\pi^2 \sigma_1^2 x^2} - \sqrt{2\pi} \sigma_2 B e^{-2\pi^2 \sigma_2^2 x^2}$$

We usually design a filter in the frequency domain and implement it in the spatial domain.



Chapter 4
Image Enhancement in the
Frequency Domain

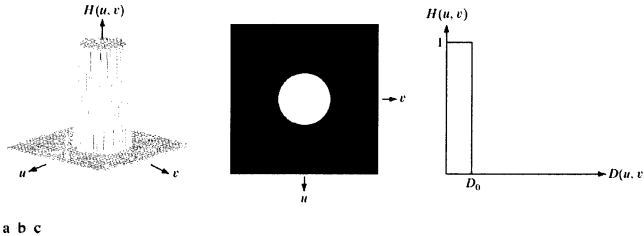

FIGURE 4.10 (a) Perspective plot of an ideal lowpass filter transfer function. (b) Filter displayed as an image. (c) Filter radial cross section.

Ideal Low Pass Filter

© 2002 R. C. Gonzalez & R. E. Woods

Two-dimensional ideal low-pass filter

$$H(u, v) = \begin{cases} 1 & D(u, v) \leq D_0 \\ 0 & D(u, v) \geq D_0 \end{cases}$$

where $D(u, v) = \sqrt{(u - \frac{m}{2})^2 + (v - \frac{N}{2})^2}$ D_0 is the cutoff frequency.

Pick cutoff frequencies based upon fraction of image power they remove.

$$P(u, v) = |F(u, v)|^2$$

$$P_T = \sum_{u=0}^{m-1} \sum_{v=0}^{N-1} P(u, v)$$

$$\% \text{ of image power } \alpha = 100 \left[\frac{\sum_u \sum_v P(u, v)}{P_T} \right]$$



Chapter 4
Image Enhancement in the
Frequency Domain

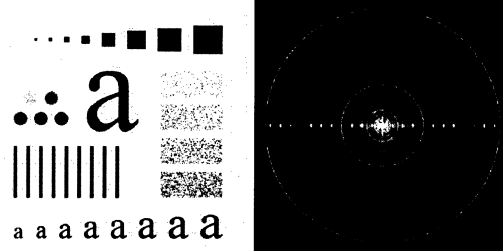

FIGURE 4.11 (a) An image of size 500×500 pixels and (b) its Fourier spectrum. The superimposed circles have radii values of 5, 15, 30, 80, and 230, which enclose 92.0, 94.6, 96.4, 98.0, and 99.5% of the image power, respectively.

© 2002 R. C. Gonzalez & R. E. Woods

There are five circles shown in the Fourier transform of this test image. These correspond to $\alpha = 92.0, 94.6, 96.4, 98.0 \& 99.5\%$
The corresponding u, v are 5, 15, 30, 80 & 230

The results of using each filter are shown in the next figure.

$$\Delta u = \frac{1}{M \Delta x}$$

↑
spatial interval.

Say $\frac{512 \text{ pixels}}{\text{inch}}$ Then $\frac{1 \text{ inch}}{512 \text{ pixel}}$

$$\Delta u = \frac{1}{512 \times 0.001953} = \frac{1}{\text{inch}} = 0.001953 \frac{\text{in}}{\text{pix}}$$

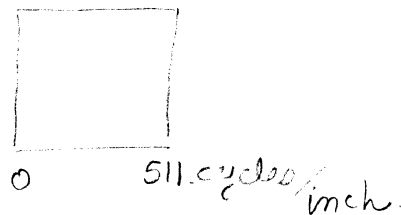



Chapter 4 Image Enhancement in the Frequency Domain

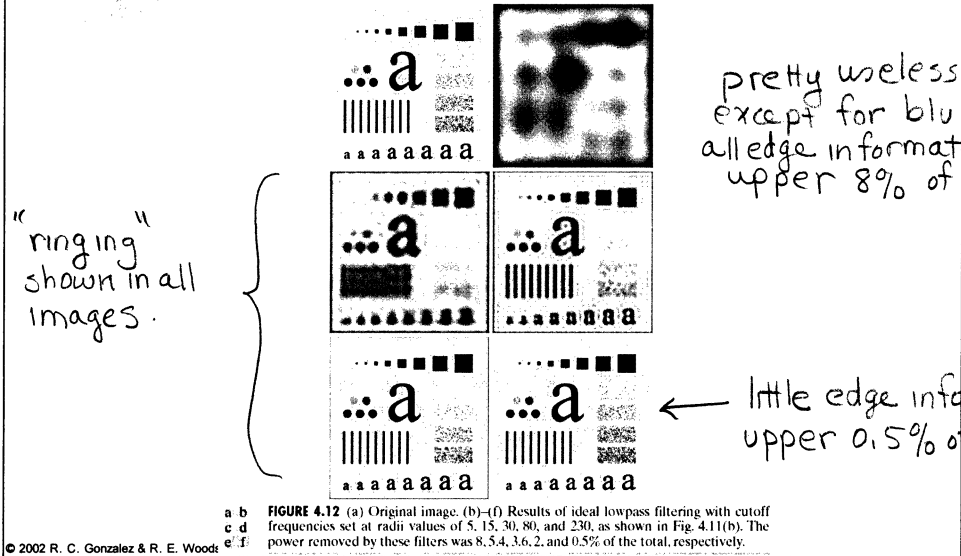

Lowpass filtering

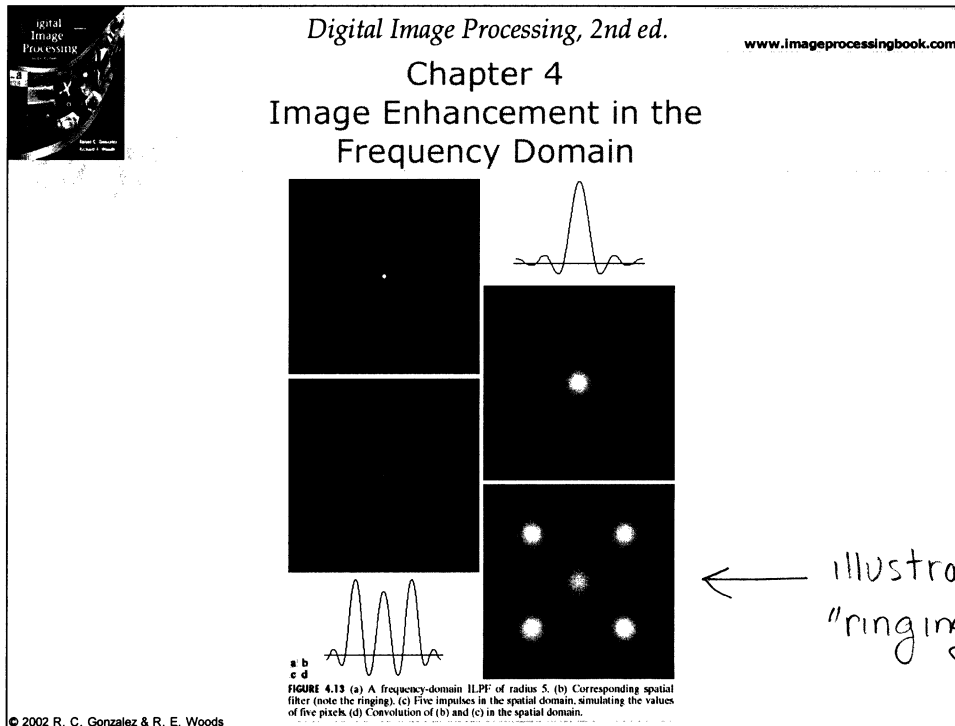

← illustrates "ringing" due to ILPF

- (a) ideal low pass filter of radius 5 pixels
 (b) corresponding spatial filter is computed
 $(-1)^{u+v} H(u,v)$ for centering
 inverse DFT

re-centers $(-1)^{x+y} \text{Re}[\text{inverse DFT}]$
 ↑ take real part since it should be real

As pixel radius of (a) increases
 the radius of the spatial rings
 decreases.

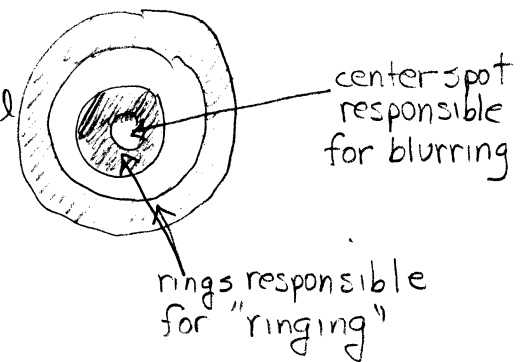

- (c) 5 pixels in spatial domain
 "impulses"
 (d) convolution of (b) with (c)
 showing "shifting" property



Chapter 4 Image Enhancement in the Frequency Domain

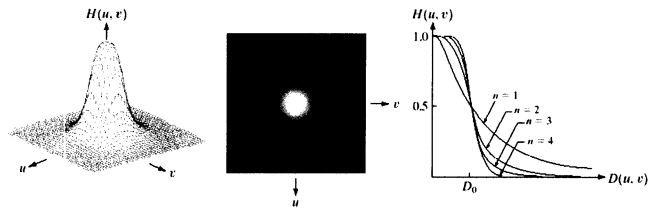

a b c

FIGURE 4.14 (a) Perspective plot of a Butterworth lowpass filter transfer function. (b) Filter displayed as an image. (c) Filter radial cross sections of orders 1 through 4.

Butterworth LPF

Ringings will increase as n increases.
 $n=1$ no ringing
 $n=2$ bare perceptible



Chapter 4 Image Enhancement in the Frequency Domain

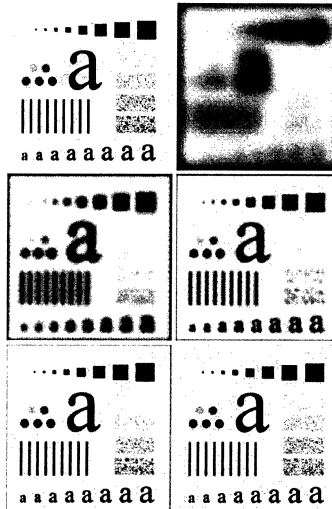

FIGURE 4.15 (a) Original image. (b)-(f) Results of filtering with BLPFs of order 2, with cutoff frequencies at radii of 5, 15, 50, 80, and 250, as shown in Fig. 4.11(b).

© 2002 R. C. Gonzalez & R. E. Woods

Results of $n=2$ Butterworth low pass filter
Using same radii (D_0) as for ideal low-pass filter.

Blurring linearly decreases as radius increases,
No ringing visible.



Chapter 4 Image Enhancement in the Frequency Domain

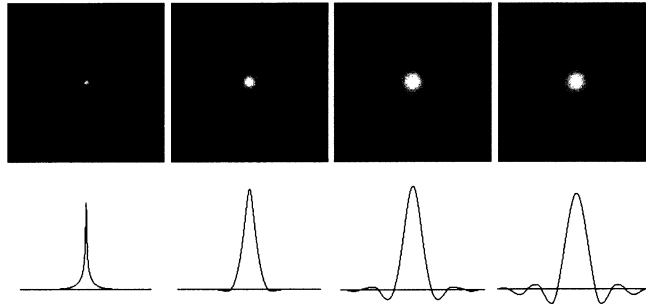

a b c d

FIGURE 4.16 (a)–(d) Spatial representation of BLPFs of order 1, 2, 5, and 20, and corresponding gray-level profiles through the center of the filters (all filters have a cutoff frequency of 5). Note that ringing increases as a function of filter order.

© 2002 R. C. Gonzalez & R. E. Woods

Spatial implementations of Butterworth low-pass filters, All filters have $D_0 = 5$.

Note that ringing increases with n .



Chapter 4 Image Enhancement in the Frequency Domain

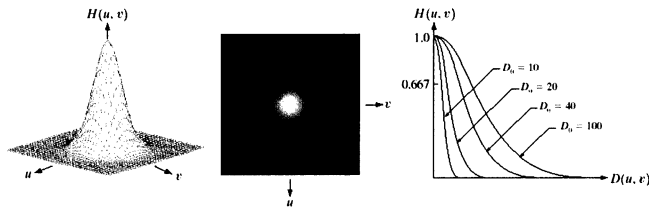

a b c

FIGURE 4.17 (a) Perspective plot of a GLPF transfer function. (b) Filter displayed as an image. (c) Filter radial cross sections for various values of D_0 .

© 2002 R. C. Gonzalez & R. E. Woods

Gaussian Low Pass filter

$$H(u, v) = e^{-\frac{D^2(u, v)}{2\sigma^2}}$$

↑

note constant is 1 for consistency with other filter types

pick $\sigma = D_0$

$$H(u, v) = e^{-\frac{D^2(u, v)}{2D_0^2}}$$

Since it's always positive we expect no ringing in the resulting image.



Chapter 4 Image Enhancement in the Frequency Domain

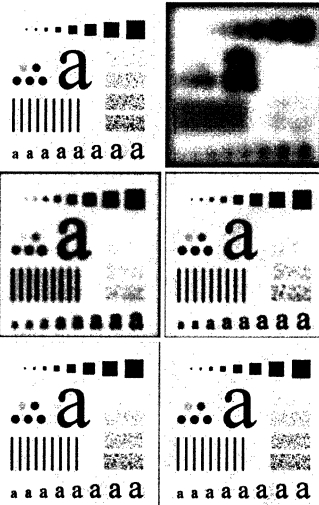

Gaussian
Low Pass Filtering

FIGURE 4.18 (a) Original image; (b)-(f) Results of filtering with Gaussian lowpass filters with cutoff frequencies set of radii values of 5, 15, 30, 60, and 200, as shown in Fig. 4.11(b). Compare with Figs. 4.12 and 4.15.

© 2002 R. C. Gonzalez & R. E. Woods

Blurring linearly decreases as radius (D_0) increases
No ringing visible

Compare 4.18 (c) Gaussian ← picture looks better
to 4.15 (c) Butterworth so not as much
smoothing



Chapter 4 Image Enhancement in the Frequency Domain

a b
FIGURE 4.19
(a) Sample text of poor resolution (note broken characters in magnified view).
(b) Result of filtering with a GLPF (broken character segments were joined).

<p>Historically, certain computer programs were written using only two digits rather than four to define the applicable year. Accordingly, the company's software may recognize a date using "00" as 1900 rather than the year 2000.</p>	<p>Historically, certain computer programs were written using only two digits rather than four to define the applicable year. Accordingly, the company's software may recognize a date using "00" as 1900 rather than the year 2000.</p>

444 x 508 pixels.

broken characters are bad.

fuller and more filled in images using GLPF with $D_0 = 80$

Example of using Gaussian LPF to improve text for OCR.

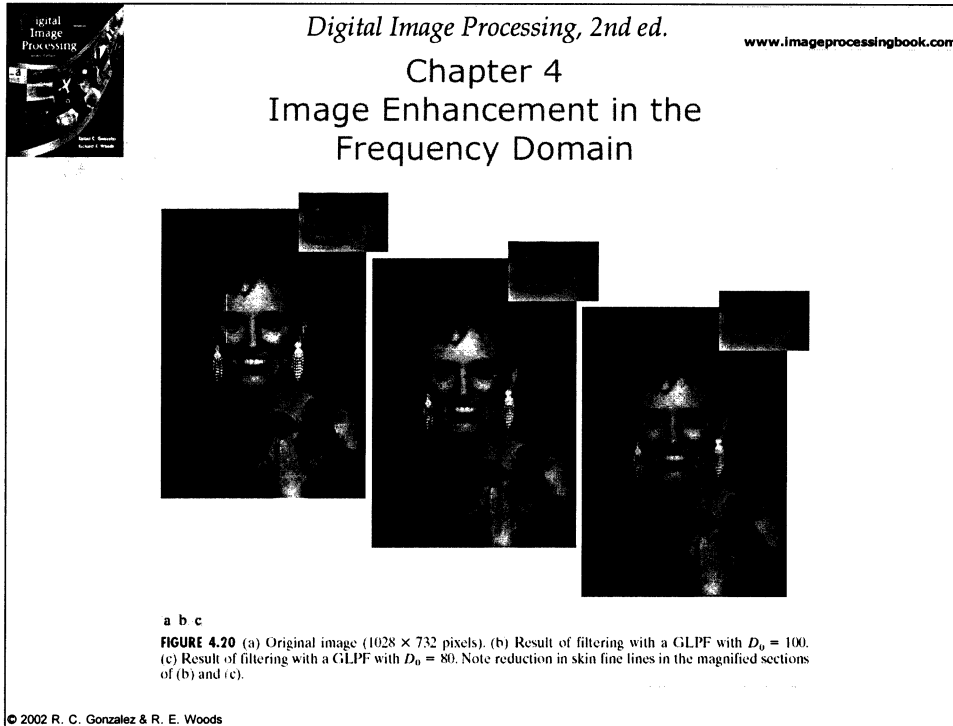

Another commercial application of low pass filtering.
Apply a GLPF to eliminate skin lines and blemishes
by selectively smoothing images.



Chapter 4 Image Enhancement in the Frequency Domain



a b c

FIGURE 4.21 (a) Image showing prominent scan lines. (b) Result of using a GLPF with $D_0 = 30$. (c) Result of using a GLPF with $D_0 = 10$. (Original image courtesy of NOAA.)

© 2002 R. C. Gonzalez & R. E. Woods

588 x 600
pixel original

GLPF
 $D_0 = 30$

GLPF
 $D_0 = 10$

might use this image
for registration with
a map

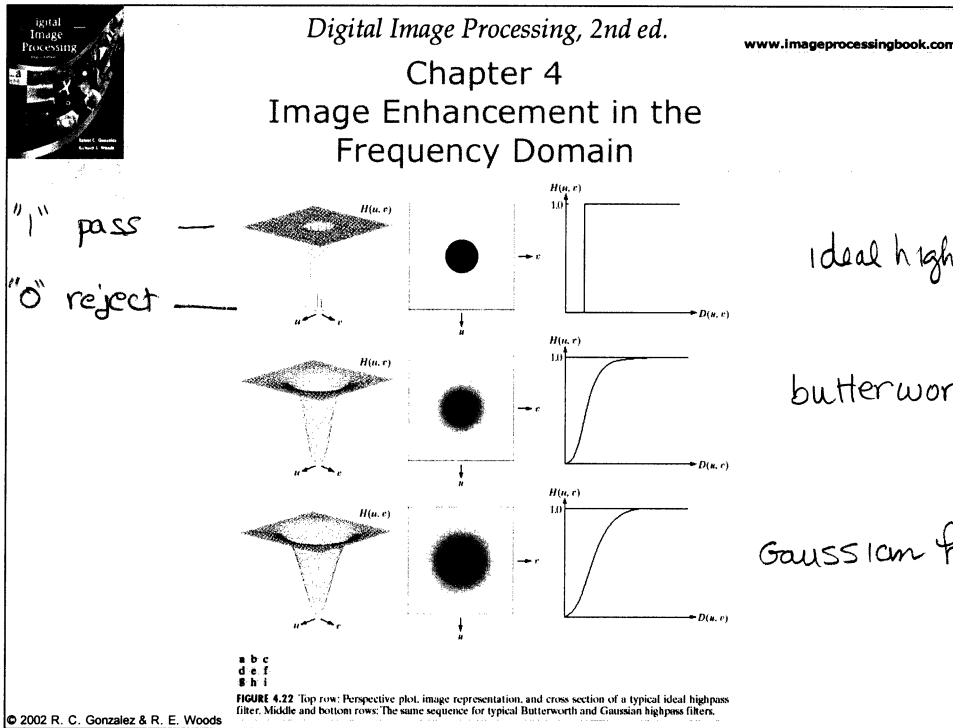

In the spatial domain we did unsharp masking as

$$f_s(x, y) = f(x, y) - \bar{f}(x, y)$$

↑
 sharpens detail

by subtracting averaged image

In the frequency domain we can write something roughly comparable

$$H_{hp}(u, v) = 1 - H_{lp}(u, v)$$

Generate spatial masks by

1. multiply $H(u, v)$ by $(-1)^{u+v}$ to center
2. compute inverse DFT
3. multiply real part of inverse DFT by $(-1)^{x+y}$



Chapter 4 Image Enhancement in the Frequency Domain

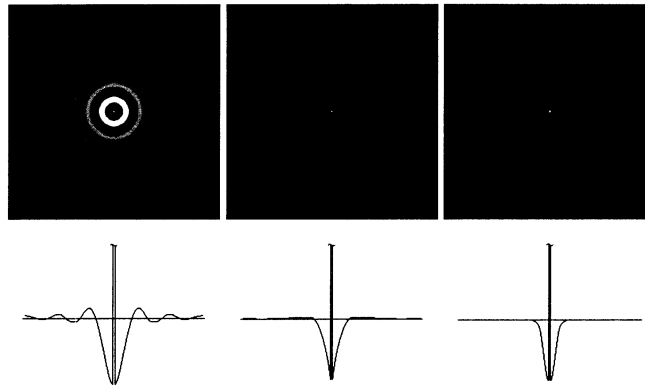

a b c

FIGURE 4.23 Spatial representations of typical (a) ideal, (b) Butterworth, and (c) Gaussian frequency domain highpass filters, and corresponding gray-level profiles.

- Spatial filters generated by $u+iv$
1. multiply $H(u,v)$ by $(-1)^{u+iv}$ to center
 2. inverse DFT
 3. multiply inverse DFT by $(-1)^{x+iy}$



Chapter 4 Image Enhancement in the Frequency Domain

original
test image
500 x 500
pixels



a b c

FIGURE 4.24 Results of ideal highpass filtering the image in Fig. 4.11(a) with $D_0 = 15, 30,$ and $80,$ respectively. Problems with ringing are quite evident in (a) and (b).

$D_0 = 15$ $D_0 = 30$ $D_0 = 80$
Nice edges
Good

© 2002 R. C. Gonzalez & R. E. Woods

2D ideal high-pass filter (IHPF)

$$H(u,v) = \begin{cases} 0 & \text{if } D(u,v) \leq D_0 \\ 1 & \text{if } D(u,v) > D_0 \end{cases}$$

high-pass filtering emphasizes edge discontinuity information



Chapter 4 Image Enhancement in the Frequency Domain

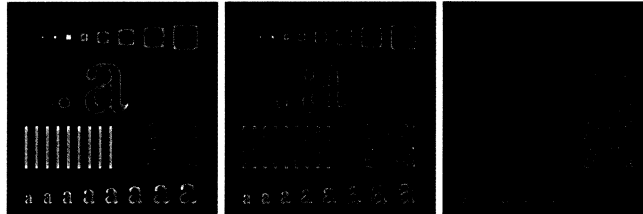

a b c

FIGURE 4.25 Results of highpass filtering the image in Fig. 4.11(a) using a BHPF of order 2 with $D_0 = 15$, 30, and 80, respectively. These results are much smoother than those obtained with an ILPF.

$D_0 = 15$ $D_0 = 30$ $D_0 = 80$

Much less ringing for small D_0 than IHPF

© 2002 R. C. Gonzalez & R. E. Woods

Butterworth high pass filter (BHPF) of order n

$$H(u, v) = \frac{1}{1 + \left[\frac{D_0}{D(u, v)} \right]^{2n}}$$



Chapter 4 Image Enhancement in the Frequency Domain

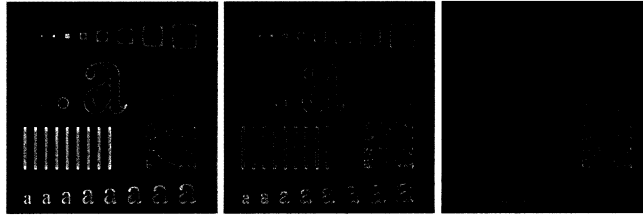

a b c

FIGURE 4.26 Results of highpass filtering the image of Fig. 4.11(a) using a GHPF of order 2 with $D_0 = 15$, 30, and 80, respectively. Compare with Figs. 4.24 and 4.25.

$D_0 = 15$ $D_0 = 30$ $D_0 = 80$

Very clean and smooth results.

Gaussian high-pass filter (GHPF)

$$H(u, v) = 1 - e^{-\frac{D^2(u, v)}{2D_0^2}}$$

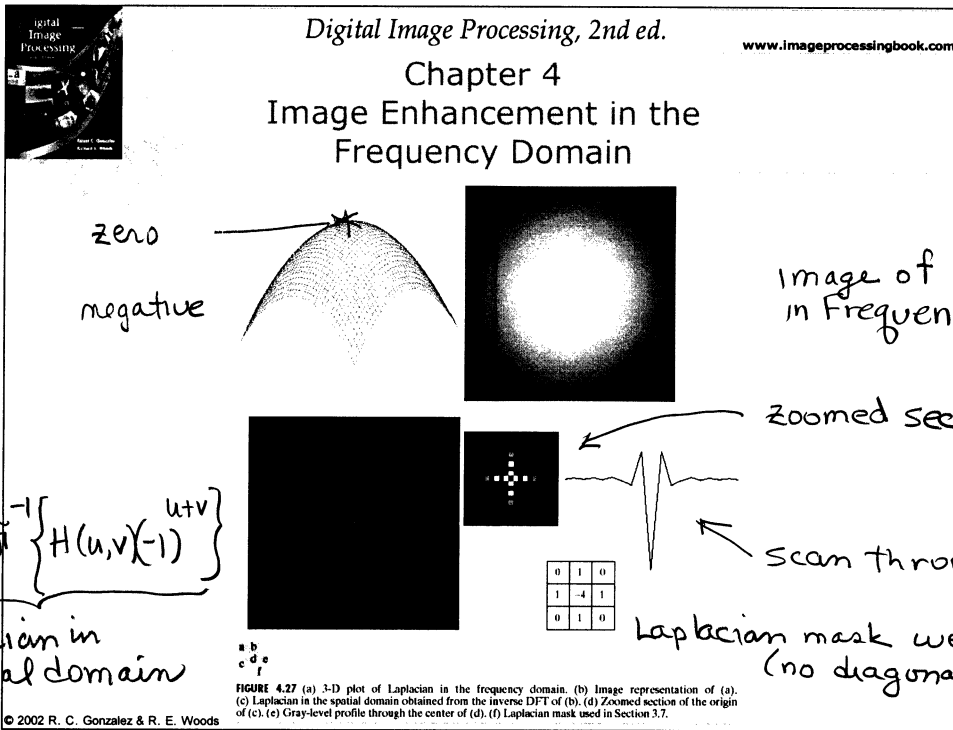

What does the Laplacian look like in the frequency domain?

Using $\mathcal{F} \left[\frac{d^n f(x)}{dx^n} \right] = (j\omega)^n F(\omega)$

we can write $\mathcal{F} \left[\frac{\partial^2 f(x,y)}{\partial x^2} + \frac{\partial^2 f(x,y)}{\partial y^2} \right] = (j\omega)^2 F(u,v) + (j\omega)^2 F(u,v)$

or $\mathcal{F} \left[\nabla^2 f(x,y) \right] = -(u^2 + v^2) F(u,v)$

We shift this to the center by multiplying $f(x,y)$ by $(-1)^{x+y}$ before we Fourier transform

$\Rightarrow \nabla^2 f(x,y) \Leftrightarrow - \left[\left(u - \frac{m}{2}\right)^2 + \left(v - \frac{N}{2}\right)^2 \right] F(u,v)$

multiply
by $(-1)^{x+y}$

Laplacian plotted in (a)



Chapter 4 Image Enhancement in the Frequency Domain

a b
c d
FIGURE 4.28
(a) Image of the North Pole of the moon.
(b) Laplacian filtered image.
(c) Laplacian image scaled.
(d) Image enhanced by using Eq. (4.4-12).
(Original image courtesy of NASA.)

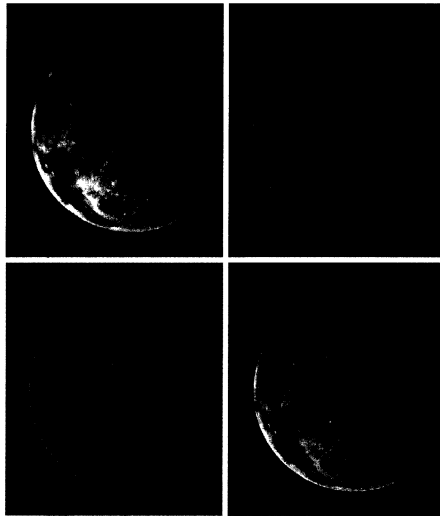

scaled image
most positive $\rightarrow 1$
most negative $\rightarrow 0$

Laplacian
Filtering in the (u, v) domain
$$\nabla^2 f(x, y) = \mathcal{F}^{-1} \left\{ - \left[\left(u - \frac{M}{2} \right)^2 + \left(v - \frac{N}{2} \right)^2 \right] F(u, v) \right\}$$

(4.4-12)
$$g(x, y) = f(x, y) - \nabla^2 f(x, y)$$

$$g(x, y) = f(x, y) - \nabla^2 f(x, y)$$

use one frequency domain mask

$$H(u, v) = 1 - \left[\left(u - \frac{M}{2} \right)^2 + \left(v - \frac{N}{2} \right)^2 \right]$$

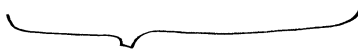

be careful in scaling since these can be $\gg 1$

This result is the same one as done before in the spatial domain EXCEPT now done in the frequency domain.



Chapter 4
Image Enhancement in the
Frequency Domain

a b
c d
FIGURE 4.29
Same as Fig. 3.43,
but using
frequency domain
filtering. (a) Input
image. (b) Laplacian of
(a). (c) Image
obtained using
Eq. (4.4-17) with
 $A = 2$. (d) Same
as (c), but with
 $A = 2.7$. (Original
image courtesy of
Mr. Michael
Shaffer,
Department of
Geological
Sciences,
University of
Oregon, Eugene.)

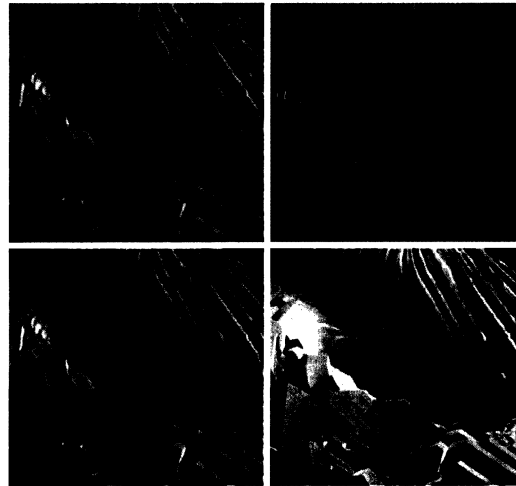

high-boost image
with $A = 2$

Laplacian
high-pass filtered
image

high-boost image
with A increased to 2.7

© 2002 R. C. Gonzalez & R. E. Woods

unsharp masking $f_{hp}(x,y) = f(x,y) - f_{lp}(x,y)$ (1)

high boost filtering $f_{hb} = Af(x,y) - f_{lp}(x,y)$

re-writing $f_{hb} = (A-1)f(x,y) + \underbrace{f(x,y) - f_{lp}(x,y)}_{f_{hp}(x,y)}$

In the frequency domain
we can use a composite filter $H_{hb}(u,v) = (A-1)f(x,y) H_{hp}(u,v)$ where $A \geq 1$

This is slightly different than previous spatial domain results because this frequency domain representation of the Laplacian does not include diagonal components,



Chapter 4 Image Enhancement in the Frequency Domain

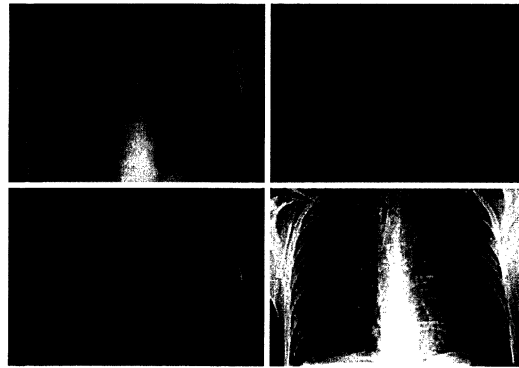

FIGURE 4.30
(a) A chest X-ray image. (b) Result of Butterworth highpass filtering. (c) Result of high-frequency emphasis filtering. (d) Result of performing histogram equalization on (c). (Original image courtesy Dr. Thomas R. Gest, Division of Anatomical Sciences, University of Michigan Medical School.)

high frequency emphasis
 $a = 0.5$ $b = 2$
keeps low freq. tones

butterworth high pass
 $n = 2$

histogram equalization
of high frequency emphasis image

© 2002 R. C. Gonzalez & R. E. Woods

high boost $H_{hb}(u,v) = (A-1)f(x,y) + H_{hp}(u,v)$

high-frequency emphasis

$$H_{hfe}(u,v) = a + b H_{hp}(u,v)$$

↑ multiply high frequencies by a constant
↑ add an offset so zero frequency term is not eliminated

typically $0.25 < a < 0.5$ $1.5 < b < 2.0$

when $b = 1$ this reduces to high-frequency boost

$b > 1$ this emphasizes high frequencies



Chapter 4
Image Enhancement in the
Frequency Domain

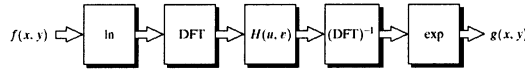

FIGURE 4.31 Homomorphic filtering approach for image enhancement.

- simultaneous:
- ① dynamic range compression
 - ② contrast enhancement

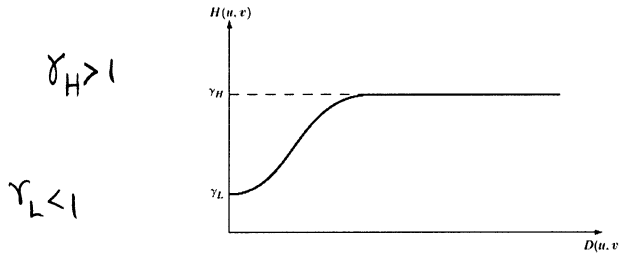
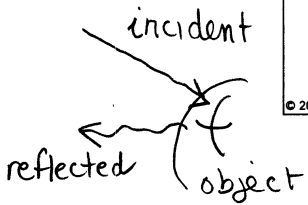

FIGURE 4.32 Cross section of a circularly symmetric filter function. $D(u, v)$ is the distance from the origin of the centered transform.

decrease illumination low frequencies increase reflectance which varies abruptly for this example high frequencies

© 2002 R. C. Gonzalez & R. E. Woods



$$f(x,y) = \underbrace{i(x,y)}_{\text{illumination}} \underbrace{r(x,y)}_{\text{reflection from object}}$$

illumination reflection from object

define $z(x,y) = \ln(f(x,y)) = \ln i(x,y) + \ln r(x,y)$
(used log to separate i and r)

Fourier transform $\mathcal{F}\{z(x,y)\} = \mathcal{F}\{\ln i(x,y)\} + \mathcal{F}\{\ln r(x,y)\}$

$$Z(u,v) = F_i(u,v) + F_r(u,v)$$

Now process by a filter $H(u,v)$

$$S(u,v) = H(u,v)Z(u,v) = \underbrace{H(u,v)F_i(u,v)}_{\text{low frequencies}} + \underbrace{H(u,v)F_r(u,v)}_{\text{high frequencies}}$$

Inverse transforming

$$s(x,y) = \mathcal{F}^{-1}\{S(u,v)\} = \underbrace{\mathcal{F}^{-1}\{H(u,v)F_i(u,v)\}}_{i'(x,y)} + \underbrace{\mathcal{F}^{-1}\{H(u,v)F_r(u,v)\}}_{r'(x,y)}$$

$$s(x,y) = i'(x,y) + r'(x,y)$$

Use exponential to invert original logarithm

$$g(x,y) = e^{s(x,y)} = e^{i'(x,y)} e^{r'(x,y)} = i_0(x,y) r_0(x,y)$$

where $i_0(x,y) = e^{i'(x,y)}$ and $r_0(x,y) = e^{r'(x,y)}$

inverse



Chapter 4 Image Enhancement in the Frequency Domain

a b
FIGURE 4.33
(a) Original image. (b) Image processed by homomorphic filtering (note details inside shelter). (Stockham.)

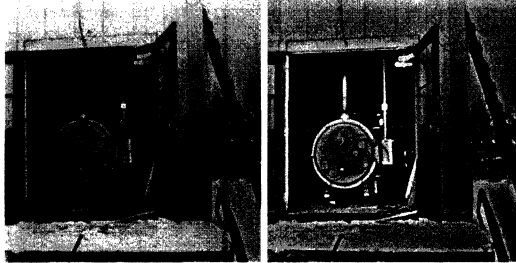

$$\gamma_L = 0.5$$

$$\gamma_H = 2$$

similar to high-frequency emphasis filter

Result of homomorphic processing:

$$H(u,v) = (\gamma_H - \gamma_L) \left[1 - e^{-c \frac{D^2(u,v)}{D_0^2}} \right] + \gamma_L$$

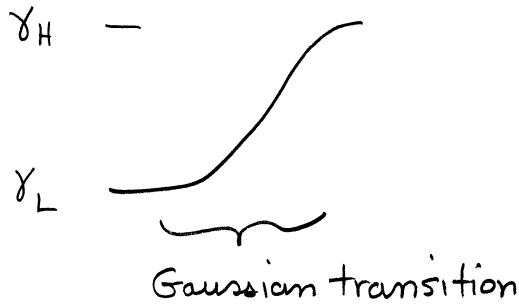



Chapter 4
Image Enhancement in the
Frequency Domain

a b
c d
FIGURE 4.34
(a) Fourier spectrum showing back-to-back half periods in the interval $[0, M-1]$.
(b) Shifted spectrum showing a full period in the same interval.
(c) Fourier spectrum of an image, showing the same back-to-back properties as (a), but in two dimensions.
(d) Centered Fourier spectrum.

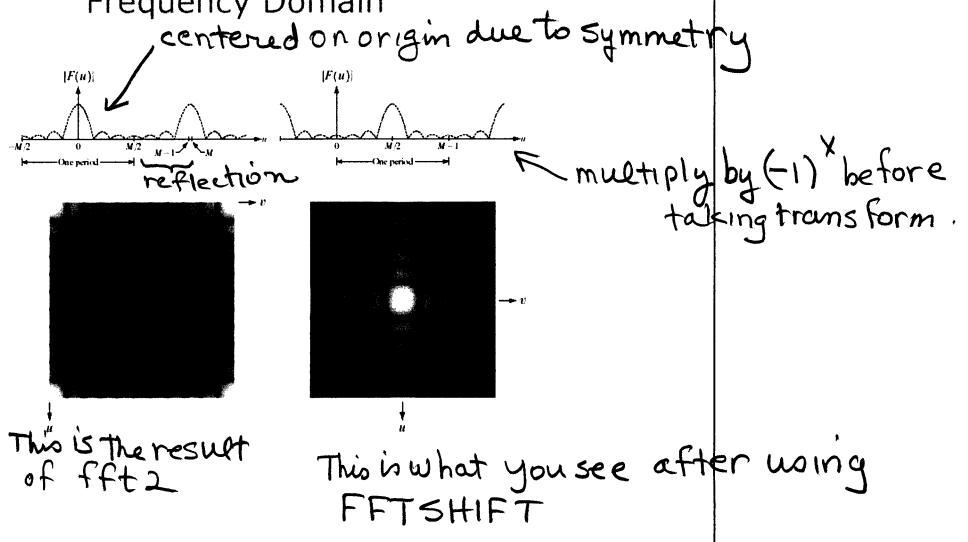

The DFT is periodic: $F(u, v) = F(u + M, v) = F(u, v + N) = F(u + M, v + N)$

The inverse DFT is periodic

$$f(x, y) = f(x + M, y) = f(x, y + N) = f(x + M, y + N)$$

The DFT is also symmetric

$$F(u, v) = F^*(-u, -v)$$

$$|F(u, v)| = |F(-u, -v)|$$

(a) In (a) we see $F(u)$ is periodic with a period of length M

$$F(u) = \frac{1}{m} \sum_{x=0}^{m-1} f(x) e^{-j \frac{2\pi u x}{M}}$$

(b) shows the result of pre multiplying by $(-1)^x$ which is simply a shift.

$$F(u) = \frac{1}{m} \sum_{x=0}^{m-1} (-1)^x f(x) e^{-j \frac{2\pi u x}{M}} = \frac{1}{m} \sum_{x=0}^{m-1} f(x) e^{-j \frac{\pi x}{2}} e^{-j \frac{2\pi u x}{M}}$$

since $-1 = e^{-j \frac{\pi}{2}}$

$$= \frac{1}{m} \sum_{x=0}^{m-1} f(x) e^{-j \frac{2\pi u x}{M} - j \frac{\pi x}{2}} = \frac{1}{m} \sum_{x=0}^{m-1} f(x) e^{-j (2\pi u + \frac{M}{2}) \frac{x}{M}}$$

shifted by $+\frac{m}{2}$



Chapter 4
Image Enhancement in the
Frequency Domain

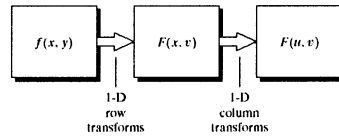

FIGURE 4.35
Computation of
the 2-D Fourier
transform as a
series of 1-D
transforms.

can do either first.

This argument also works for the inverse DFT.

SEPARABILITY

© 2002 R. C. Gonzalez & R. E. Woods

This is one of the most common 2-D DFT implementations

①

$$F(u, v) = \frac{1}{MN} \sum_{x=0}^{M-1} \sum_{y=0}^{N-1} f(x, y) e^{-j2\pi \left(\frac{ux}{M} + \frac{vy}{N} \right)}$$

$$= \frac{1}{M} \sum_{x=0}^{M-1} e^{-j2\pi \frac{ux}{M}} \left[\sum_{y=0}^{N-1} f(x, y) e^{-j2\pi \frac{vy}{N}} \right]$$

This is the 1-D DFT of $F(x, y)$
 $F(x, v)$

$$= \frac{1}{M} \sum_{x=0}^{M-1} F(x, v) e^{-j2\pi \frac{ux}{M}}$$

This is the column DFT
of $f(x, y)$
y going from 0 to N

This is the subsequent
row DFT.
x going from 0 to M

② The DFT of the DFT yields $\frac{1}{MN} f^*(x, y)$
Since f is real this is not a problem. Multiply by MN to get $f(x, y)$

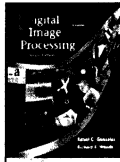

Chapter 4 Image Enhancement in the Frequency Domain

a f
b g
c h
d i
e j

FIGURE 4.36 Left: convolution of two discrete functions. Right: convolution of the same functions, taking into account the implied periodicity of the DFT. Note in (j) how data from adjacent periods corrupt the result of convolution.

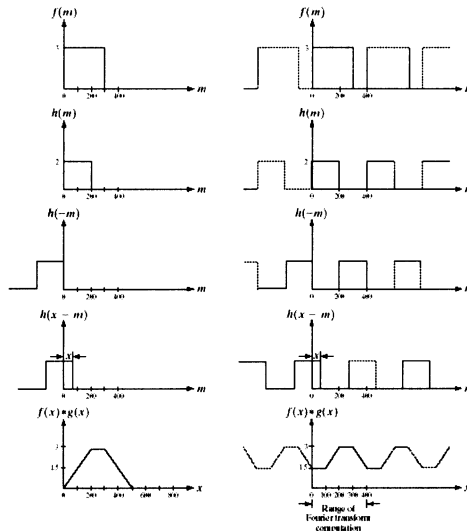

Note: period is 400

the wrap around error comes from overlap of the periodic functions

© 2002 R. C. Gonzalez & R. E. Woods

analytical convolution

Note that if f and g are 400 points
 $f * g$ goes out to 800 points

DFT makes functions periodic so we are really convolving periodic functions

convolution:

$$\text{continuous: } f(x) * h(x) = \int_{-\infty}^{+\infty} f(\sigma)h(x-\sigma)d\sigma$$

$$\text{discrete: } f(x) * h(x) = \frac{1}{M} \sum_{m=0}^{M-1} f(m)h(x-m)$$

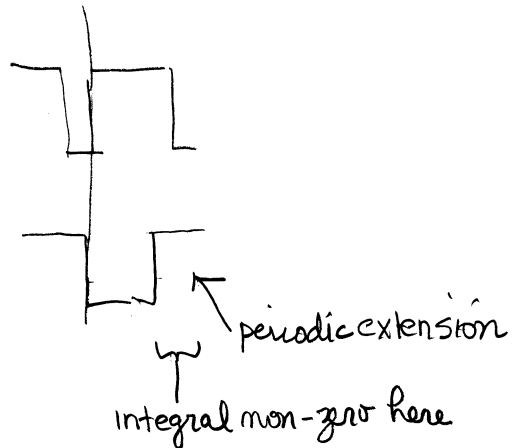

Get rid of this non-zero overlap by simply adding zeros to both functions until the overlap term goes away.



Chapter 4 Image Enhancement in the Frequency Domain

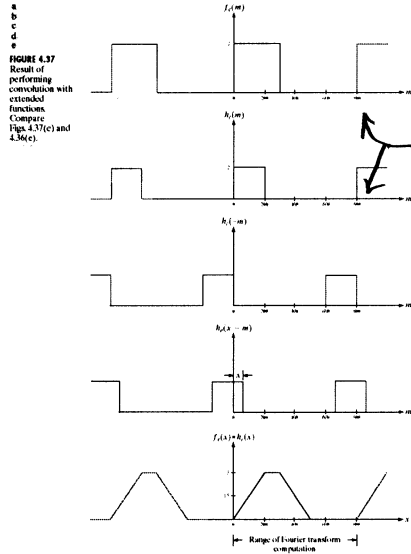

FIGURE 4.37
Result of
performing
convolution with
extended
functions.
Compare
Figs. 4.37(c) and
4.36(e).

© 2002 R. C. Gonzalez & R. E. Woods

Padded functions

$$f_e(x) = \begin{cases} f(x) & 0 \leq x \leq A-1 \\ 0 & A \leq x \leq P \end{cases}$$

$$g_e(x) = \begin{cases} g(x) & 0 \leq x \leq B-1 \\ 0 & B \leq x \leq P \end{cases}$$

} both have period P after padding

P is the new extended (or padded) period

If $P = A + B - 1$ there will be no wraparound area



Chapter 4 Image Enhancement in the Frequency Domain

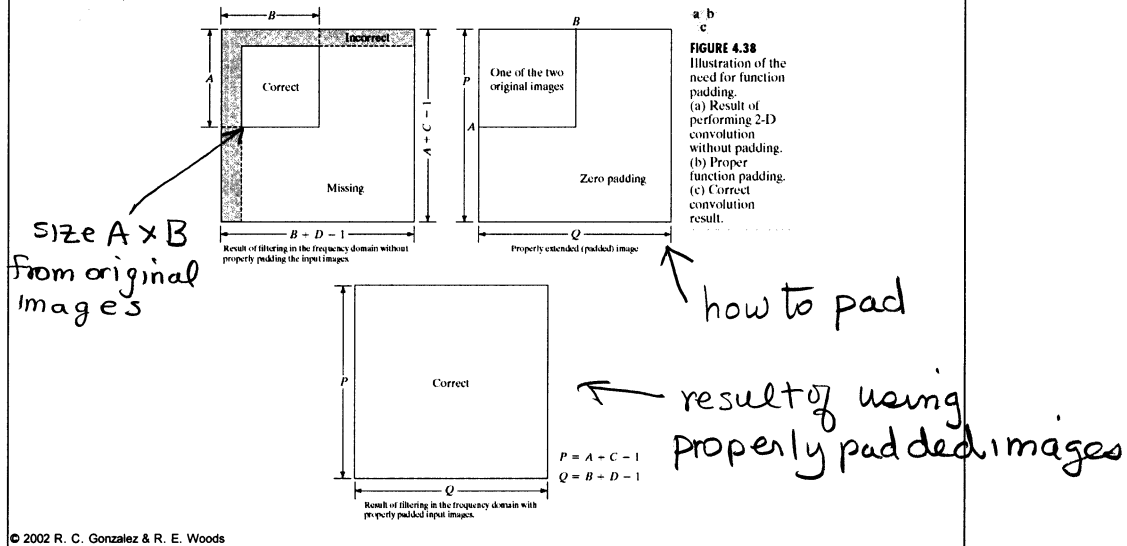

(a) f, h are square and the same size

This is the result of $\text{ifft2} [\text{fft2}(f) * \text{fft2}(h)]$

There is a band of wrap around error.

(b) f, h are properly padded

$$P \geq A + C - 1$$

$$Q \geq B + D - 1$$

for images $A \times B$ and $C \times D$



Chapter 4 Image Enhancement in the Frequency Domain

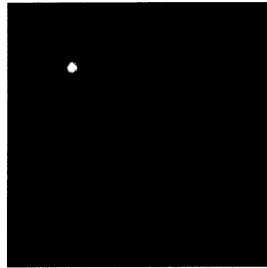

FIGURE 4.39 Padded lowpass filter in the spatial domain (only the real part is shown).

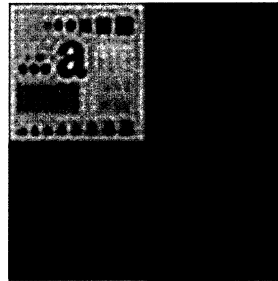

FIGURE 4.40 Result of filtering with padding. The image is usually cropped to its original size since there is little valuable information past the image boundaries.

© 2002 R. C. Gonzalez & R. E. Woods

properly padded
low pass filter

result of filtering (using padded filter)
a padded test image

Crop back to size
of original image.

